

### LB-M/100 Data sheet

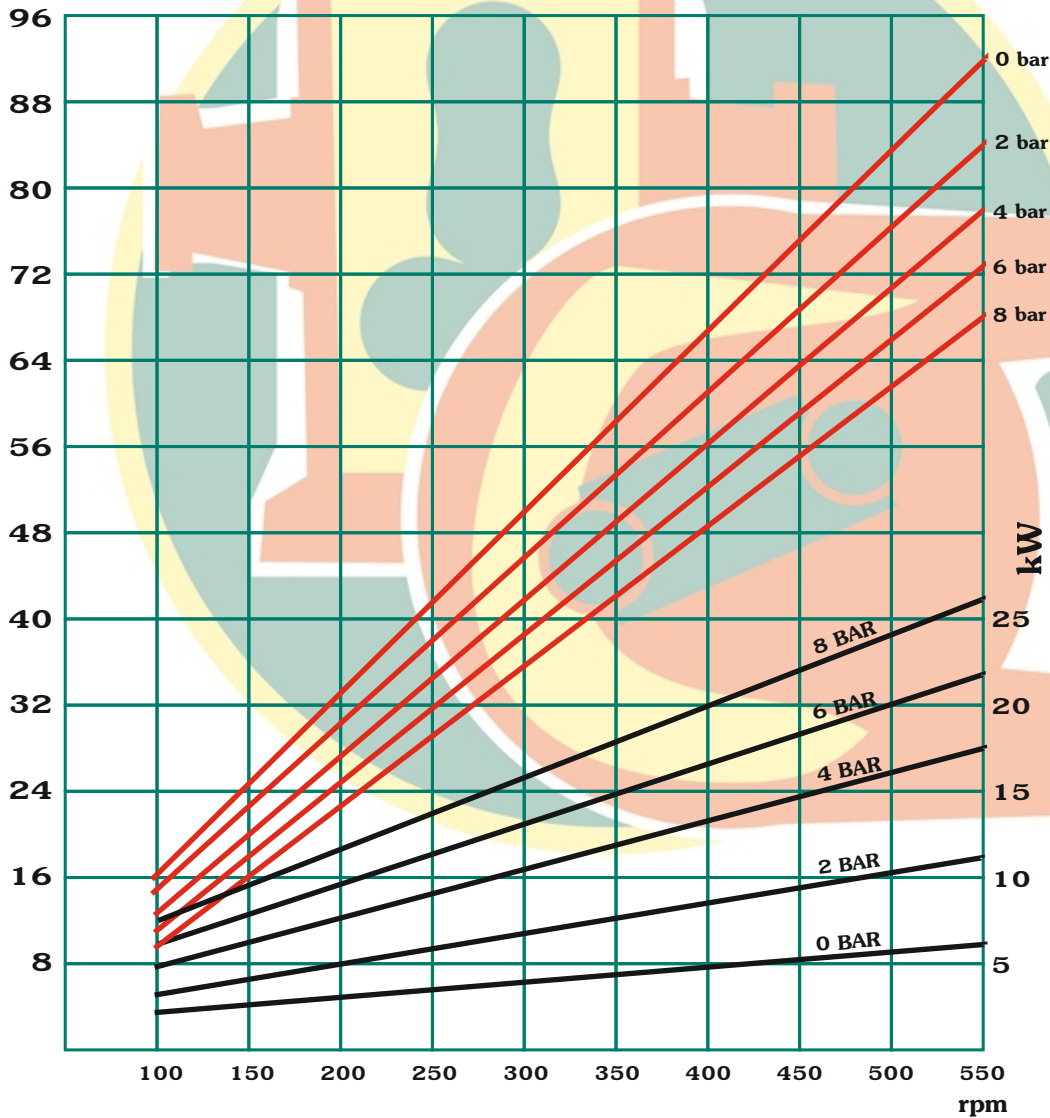

<b>Capacity:</b>	2,79 l/rev.
<b>Std. Connections:</b>	DN-80 / DN-100
<b>Max. Pressure:</b>	8 bar
<b>Lobe type:</b>	High performance Bi-lobe
<b>Available lobes:</b>	NBR Food EPDM VITON
<b>Max. solid size:</b>	50mm.

m<sup>3</sup>/h



Description	Material	Surface treatment
Pump housing	Stainless Steel AISI-410 or AISI-316	Polyester painted
Mechanical seals	Sil. Carbide / Tungs. Carbide Graphite / Tungs. Carbide ( Optional )	--
Wear plates	Stainless Steel AISI-410 or AISI-316	Hardened ( Optional )
Gaskets	NBR, EPDM or Viton	--
Base plate	Steel Stainless Steel AISI-304 ( Optional )	Polyester powder coated --
Connections	Stainless Steel AISI-316	--

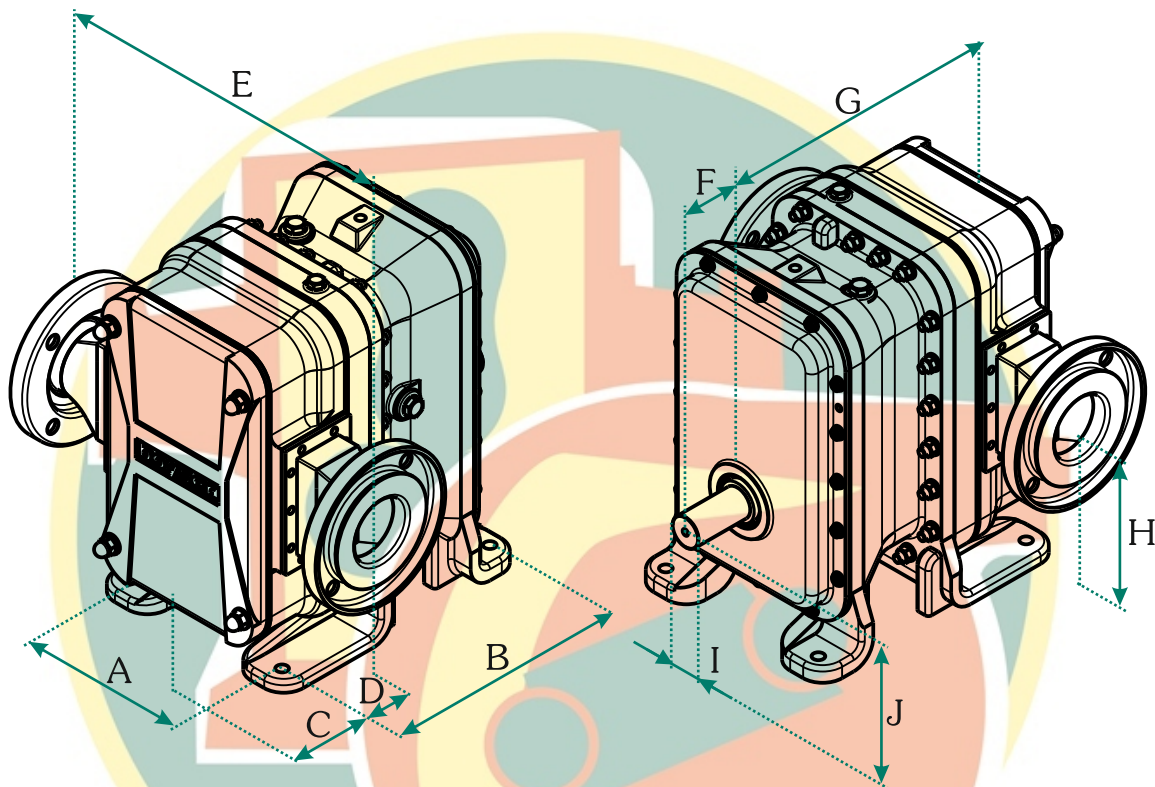

<b>Dimensions</b>										
A	B	C	D	E	F	G	H	I	J	Connections
235	320	42	34	520	80	372	240	40	170	DN-80 or DN-100



Bombas Boyser, S.L. C/. Narcís Monturiol, 24 · Pol. Ind. Can Magre  
Telf.: 93 844 77 78 · 08187 Sta. Eulàlia de Ronçana (BARCELONA)  
[info@boyser.com](mailto:info@boyser.com) · [www.boyser.com](http://www.boyser.com)

