

P1

Engineering Operation & Maintenance

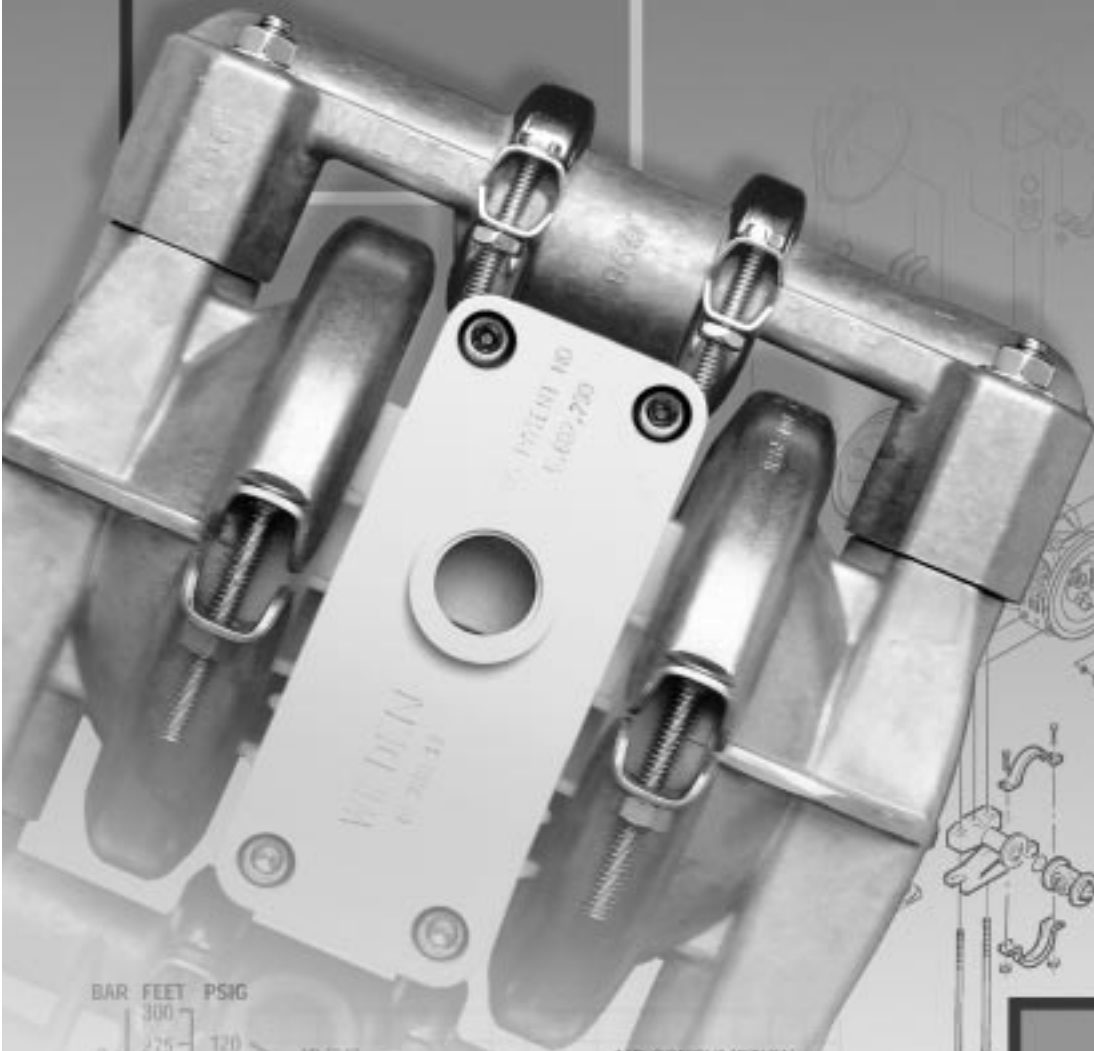

WILDEN®

AIR OPERATED DOUBLE DIAPHRAGM PUMPS

A DOVER RESOURCES COMPANY

Flow Rate (GPM)	Flow Rate (L/min)	Flow Rate (m³/h)
2	7.6	0.47
4	15.2	0.94
6	22.8	1.41
8	30.4	1.88
10	38.0	2.35
12	45.6	2.82
14	53.2	3.29
16	60.8	3.76

PROFLO™
PROGRESSIVE PUMP TECHNOLOGY

**Metal
Pumps**

TABLE OF CONTENTS

	PAGE #
SECTION # 1 – PUMP DESIGNATION SYSTEM.....	1
SECTION # 2 – HOW IT WORKS (PUMP & AIR SYSTEMS)	2
SECTION # 3 – CAUTIONS	3
SECTION # 4 – DIMENSIONAL DRAWINGS	
A. Model P1 METAL.....	4
B. Model P1 METAL SANIFLO ^{FDA}	4
SECTION # 5 – PERFORMANCE CURVES	
A. Model P1 METAL Rubber-Fitted.....	5
B. Model P1 METAL TPE-Fitted.....	5
C. Model P1 METAL Teflon [®] -Fitted.....	6
SECTION # 6 – SUCTION LIFT CURVES & DATA.....	6
SECTION # 7 – INSTALLATION & OPERATION	
A. Installation.....	7
B. Operation & Maintenance.....	8
C. Troubleshooting	9
SECTION # 8 – DIRECTIONS FOR DISASSEMBLY/REASSEMBLY	
A. Model P1 METAL Wetted Path — Tools Required, Torque Specs, Cautions.....	10
B. Pro-Flo [™] Air Valve/Center Section — Disassembly, Cleaning, Inspection.....	13
C. Reassembly Hints & Tips.....	15
SECTION # 9 – EXPLODED VIEW/PARTS LISTING	
A. Model P1 METAL Rubber/TPE-Fitted.....	16
B. Model P1 METAL Teflon [®] -Fitted.....	18
SECTION # 10 – ELASTOMER OPTIONS	20



SECTION 1

WILDEN PUMP DESIGNATION SYSTEM

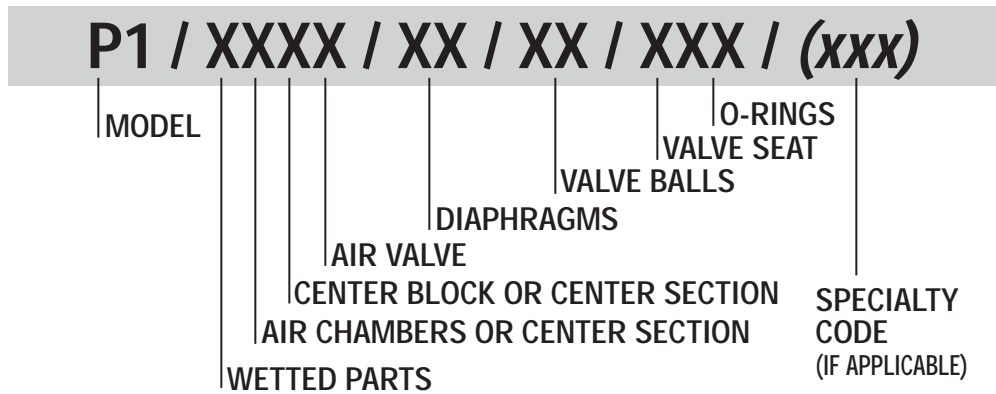

In the case where a center section is used instead of a center block and air chambers, the designation will be as follows: Acetal = LL

MODEL P1 METAL MATERIAL CODES

WETTED PARTS

- A = ALUMINUM
- H = HASTELLOY
- S = STAINLESS STEEL

AIR CHAMBERS

- L = ACETAL
- P = POLYPROPYLENE

CENTER SECTION

- L = ACETAL
- P = POLYPROPYLENE

AIR VALVE

- L = ACETAL
- P = POLYPROPYLENE

DIAPHRAGMS

- BN = BUNA-N® (Red Dot)
- FG = SANIFLEX™
- PU = POLYURETHANE
- TB = TEFLON® W/HI-TEMP BUNA-N®
- TF = TEFLON® W/NEOPRENE
- VT = VITON® (Silver Dot)
- WF = WIL-FLEX™ (Orange)

VALVE BALL

- BN = BUNA-N® (Red Dot)
- FG = SANIFLEX™
- PU = POLYURETHANE
- TF = TEFLON® PTFE (White)
- VT = VITON® (Silver or White Dot)
- WF = WIL-FLEX™ (Orange)

VALVE SEAT

- A = ALUMINUM
- H = HASTELLOY
- S = STAINLESS STEEL

VALVE SEAT O-RING

- BN = BUNA-N® (Red Dot)
- FG = SANIFLEX™
- PU = POLYURETHANE
- TF = TEFLON® PTFE
- WF = WIL-FLEX™

NOTE: ELASTOMERIC MATERIALS USE COLORED DOTS FOR IDENTIFICATION.

SECTION 2

THE WILDEN PUMP — HOW IT WORKS

The Wilden diaphragm pump is an air-operated, positive displacement, self-priming pump. These drawings show the flow pattern through the pump upon its initial stroke. It is assumed the pump has no fluid in it prior to its initial stroke.

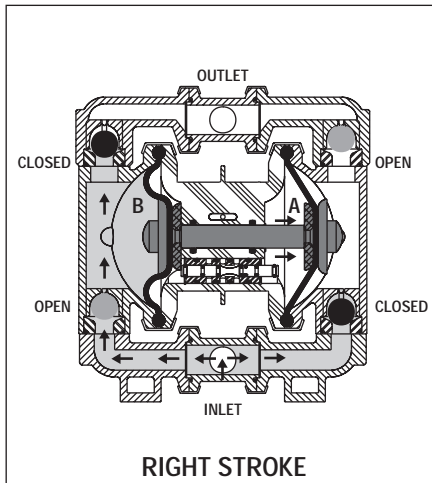

FIGURE 1 The air valve directs pressurized air to the back side of diaphragm A. The compressed air is applied directly to the liquid column separated by elastomeric diaphragms. The diaphragm acts as a separation membrane between the compressed air and liquid, balancing the load and removing mechanical stress from the diaphragm. The compressed air moves the diaphragm away from the center block of the pump. The opposite diaphragm is pulled in by the shaft connected to the pressurized diaphragm. Diaphragm B is on its suction stroke; air behind the diaphragm has been forced out to the atmosphere through the exhaust port of the pump. The movement of diaphragm B toward the center block of the pump creates a vacuum within chamber B. Atmospheric pressure forces fluid into the inlet manifold forcing the inlet valve ball off its seat. Liquid is free to move past the inlet valve ball and fill the liquid chamber (see shaded area).

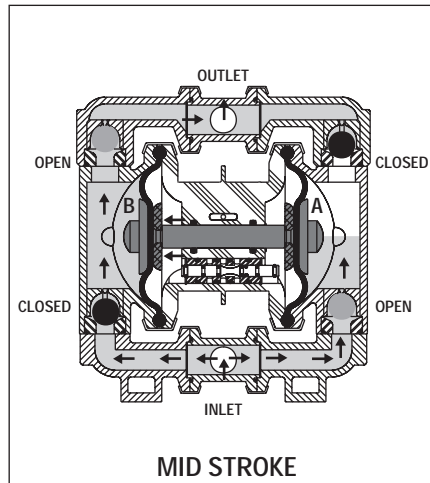

FIGURE 2 When the pressurized diaphragm, diaphragm A, reaches the limit of its discharge stroke, the air valve redirects pressurized air to the back side of diaphragm B. The pressurized air forces diaphragm B away from the center block while pulling diaphragm A to the center block. Diaphragm B is now on its discharge stroke. Diaphragm B forces the inlet valve ball onto its seat due to the hydraulic forces developed in the liquid chamber and manifold of the pump. These same hydraulic forces lift the discharge valve ball off its seat, while the opposite discharge valve ball is forced onto its seat, forcing fluid to flow through the pump discharge. The movement of diaphragm A toward the center block of the pump creates a vacuum within liquid chamber A. Atmospheric pressure forces fluid into the inlet manifold of the pump. The inlet valve ball is forced off its seat allowing the fluid being pumped to fill the liquid chamber.

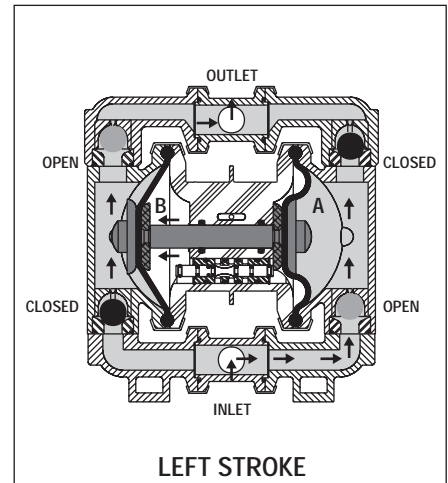
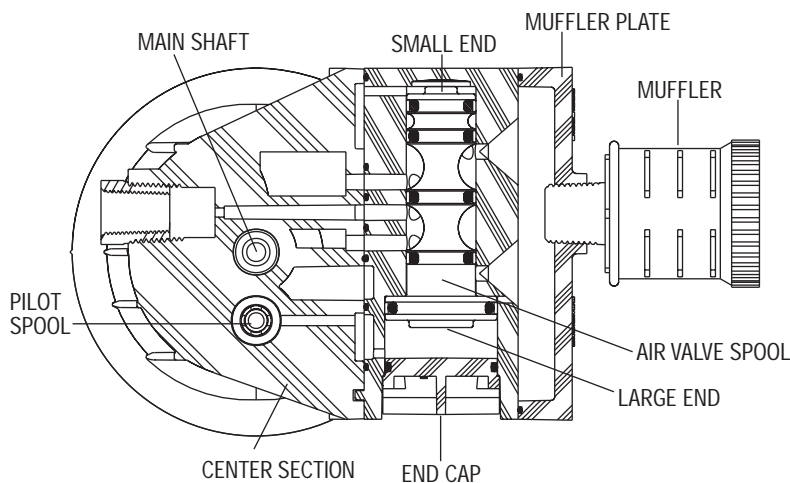

FIGURE 3 At completion of the stroke, the air valve again redirects air to the back side of diaphragm A, which starts diaphragm B on its exhaust stroke. As the pump reaches its original starting point, each diaphragm has gone through one exhaust and one discharge stroke. This constitutes one complete pumping cycle. The pump may take several cycles to completely prime depending on the conditions of the application.

PRO-FLO™ AIR DISTRIBUTION SYSTEM OPERATION — HOW IT WORKS

Figure A



The Pro-Flo™ patented air distribution system incorporates three moving parts: the air valve spool, the pilot spool, and the main shaft/diaphragm assembly. The heart of the system is the air valve spool and air valve. As shown in Figure A, this valve design incorporates an unbalanced spool. The smaller end of the spool is pressurized continuously, while the large end is alternately pressurized then exhausted to move the spool. The spool directs pressurized air to one air chamber while exhausting the other. The air causes the main shaft/diaphragm assembly to shift to one side — discharging liquid on that side and pulling liquid in on the other side. When the shaft reaches the end of its stroke, the inner piston actuates the pilot spool, which pressurizes and exhausts the large end of the air valve spool. The repositioning of the air valve spool routes the air to the other air chamber.

SECTION 3

WILDEN MODEL P1 METAL CAUTIONS – READ FIRST!



TEMPERATURE LIMITS:

Nylon	0°F to 200°F	-17.8°C to 93.3°C
Neoprene	0°F to 200°F	-17.8°C to 93.3°C
Buna-N®	10°F to 180°F	-12.2°C to 82.2°C
Nordel®	-60°F to 280°F	-51.1°C to 137.8°C
Viton®	-40°F to 350°F	-40°C to 176.7°C
Wil-Flex™	-40°F to 225°F	-40°C to 107.2°C
Polyurethane	10°F to 150°F	12.2°C to 65.6°C
Saniflex™	-20°F to 220°F	-28.9°C to 104.4°C
Teflon® PTFE	-20°F to 300°F*	-28.9°C to 148.9°C

*Teflon® PTFE upper temperature limit for UP Series with Hi-Temp Buna backup diaphragm. Standard Teflon® PTFE diaphragms with neoprene backup diaphragms are limited to 220°F (104.4°C).



CAUTION: When choosing pump materials, be sure to check the temperature limits for all wetted components. Example: Viton® has a maximum limit of 350°F (176.7°C) but polypropylene has a maximum limit of only 175°F (79°C).



CAUTION: Maximum temperature limits are based upon mechanical stress only. Certain chemicals will significantly reduce maximum safe operating temperatures. Consult engineering guide for chemical compatibility and temperature limits.



CAUTION: Always wear safety glasses when operating pump. If diaphragm rupture occurs, material being pumped may be forced out air exhaust.



WARNING: Prevention of static sparking — If static sparking occurs, fire or explosion could result. Pump, valves, and containers must be properly grounded when handling flammable fluids and whenever discharge of static electricity is a hazard.



CAUTION: Do not exceed 125 psig (8.6 Bar) air supply pressure.



CAUTION: Before any maintenance or repair is attempted, the compressed air line to the pump should be disconnected and all air pressure allowed to bleed from pump. Disconnect all intake, discharge and air lines. Drain the pump by turning it upside down and allowing any fluid to flow into a suitable container.



CAUTION: Blow out air line for 10 to 20 seconds before attaching to pump to make sure all pipe line debris is clear. Use an in-line air filter. **A 5µ (micron) air filter is recommended.**



NOTE: Tighten clamp bands and retainers prior to installation. Fittings may loosen during transportation.



NOTE: When installing Teflon® diaphragms, it is important to tighten outer pistons simultaneously (turning in opposite directions) to ensure tight fit.



NOTE: Before starting disassembly, mark a line from each liquid chamber to its corresponding air chamber. This line will assist in proper alignment during reassembly.



CAUTION: Verify the chemical compatibility of the process and cleaning fluid to the pump's component materials in the Chemical Resistance Guide (see RBG E4).



CAUTION: Do not over-tighten the air inlet reducer bushing. Too much torque on the reducer bushing may damage the air valve muffler plate. Do not exceed 29 in.-lbs. [3.3 m-N].

WARNING: You must remove the plug that covers the pilot spool exhaust (located under the air inlet bushing) or pump **will not operate.**

SECTION 4A

DIMENSIONAL DRAWING WILDEN MODEL P1 METAL

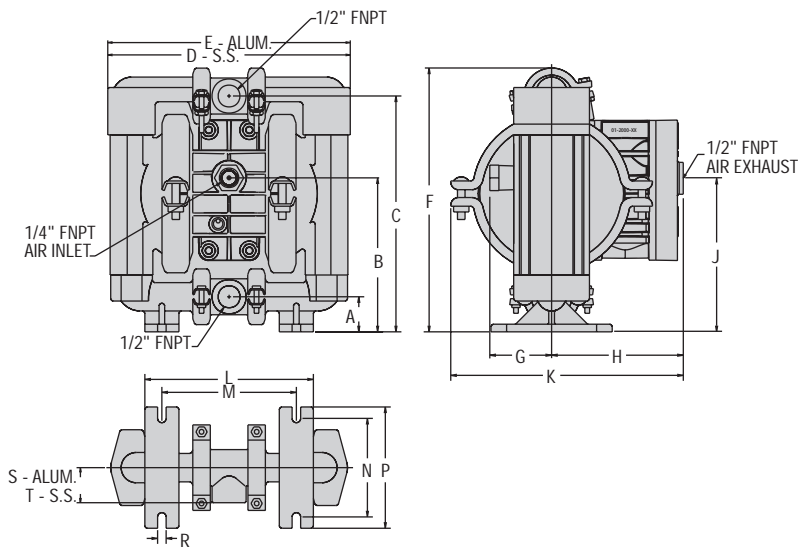

DIMENSIONS - P1 (METAL)		
ITEM	STANDARD (inch)	METRIC (mm)
A	1 1/8	28.6
B	5 3/32	129.4
C	7 13/16	198.5
D	8	203.2
E	8 5/32	207.2
F	8 3/4	222.3
G	2 3/16	55.6
H	4 17/32	115.1
J	5 3/32	129.4
K	8 1/16	204.8
L	5 1/2	139.7
M	4 13/32	111.9
N	3 1/4	82.6
P	4	101.6
R	9/32	7.1
S	1 3/16	30.2
T	1 3/16	30.2

BSP threads available.

SECTION 4B

DIMENSIONAL DRAWING WILDEN MODEL P1 METAL SANIFLO^{FD/A}

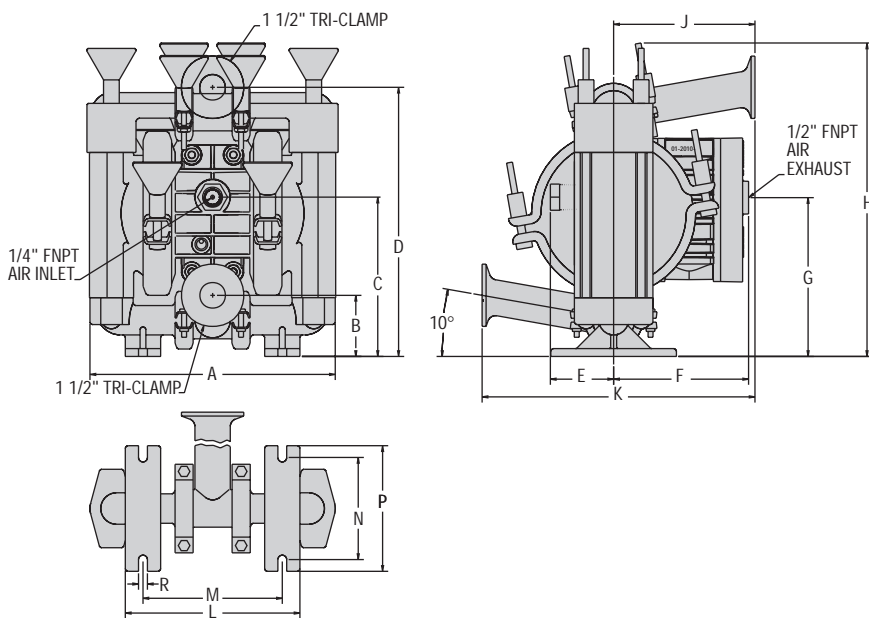

DIMENSIONS - P1 SANIFLO ^{FD/A} (METAL)		
ITEM	STANDARD (inch)	METRIC (mm)
A	8 1/32	204.0
B	1 29/32	48.4
C	5 3/16	131.8
D	8 11/16	220.7
E	2 3/32	53.2
F	4 17/32	115.1
G	4 29/32	124.6
H	10 5/32	258.0
J	4 9/16	115.9
K	9 1/32	229.4
L	5 5/8	142.9
M	4 15/32	113.5
N	3 1/4	82.6
P	4	101.6
R	9/32	7.1

SECTION 5A

PERFORMANCE CURVES

MODEL P1 METAL RUBBER-FITTED

Height8¾" (222.3 mm)
 Width8½" (207.2 mm)
 Depth.....8⅞" (204.8 mm)
 Ship WeightAluminum 13 lbs. (6 kg)
 Stainless Steel 20 lbs. (9.2 kg)
 Air Inlet¼" (6.35 mm)
 Inlet½" (1.27 cm)
 Outlet.....½" (1.27 cm)
 Suction Lift19' Dry (5.79 m)
 31' Wet (9.45 m)

Displacement per
 Stroke 0.029 gal. (.11 l)¹
 Max. Flow Rate.....15.5 gpm (58.67 lpm)
 Max. Size Solids.....⅙" (1.59 mm)
¹Displacement per stroke was calculated at 70 psig (4.8 Bar) air inlet pressure against a 30 psig (2 Bar) head pressure.

Example: To pump 5 gpm (18.9 lpm) against a discharge pressure head of 40 psig (2.7 Bar) requires 60 psig (4 Bar) and 3.5 scfm (5.92 Nm³/h) air consumption. (See dot on chart.)

Caution: Do not exceed 125 psig (8.6 Bar) air supply pressure.

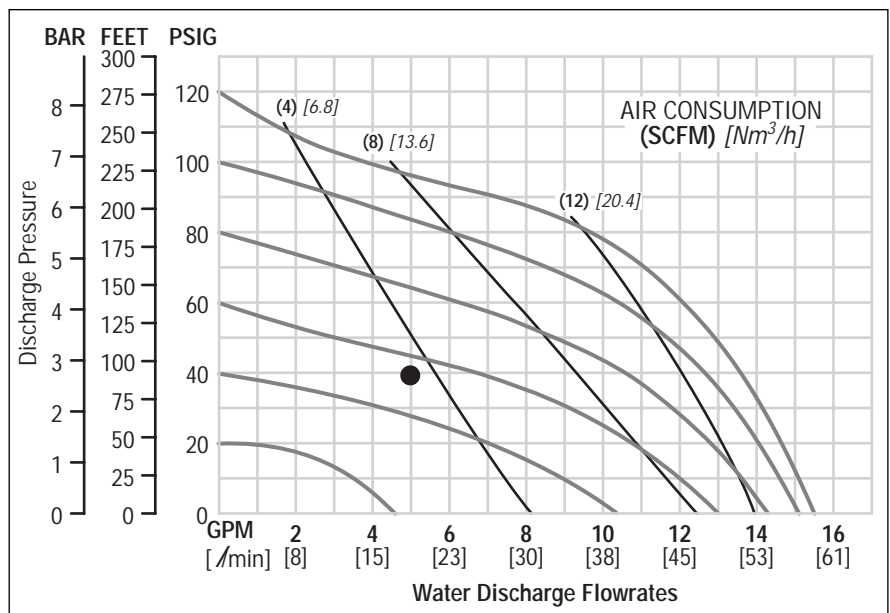

Flow rates indicated on chart were determined by pumping water.

For optimum life and performance, pumps should be specified so that daily operation parameters will fall in the center of the pump performance curve.

SECTION 5B

PERFORMANCE CURVES

MODEL P1 METAL TPE-FITTED

Height8¾" (222.3 mm)
 Width8½" (207.2 mm)
 Depth.....8⅞" (204.8 mm)
 Ship WeightAluminum 13 lbs. (6 kg)
 Stainless Steel 20 lbs. (9.2 kg)
 Air Inlet¼" (6.35 mm)
 Inlet½" (1.27 cm)
 Outlet.....½" (1.27 cm)
 Suction Lift17' Dry (5.18 m)
 31' Wet (9.45 m)

Displacement per
 Stroke..... 0.029 gal. (.11 l)¹
 Max. Flow Rate.....15.4 gpm (58.30 lpm)
 Max. Size Solids.....⅙" (1.59 mm)
¹Displacement per stroke was calculated at 70 psig (4.8 Bar) air inlet pressure against a 30 psig (2 Bar) head pressure.

Example: To pump 5 gpm (18.9 lpm) against a discharge pressure head of 40 psig (2.7 Bar) requires 56 psig (3.86 Bar) and 3.5 scfm (5.92 Nm³/h) air consumption. (See dot on chart.)

Caution: Do not exceed 125 psig (8.6 Bar) air supply pressure.

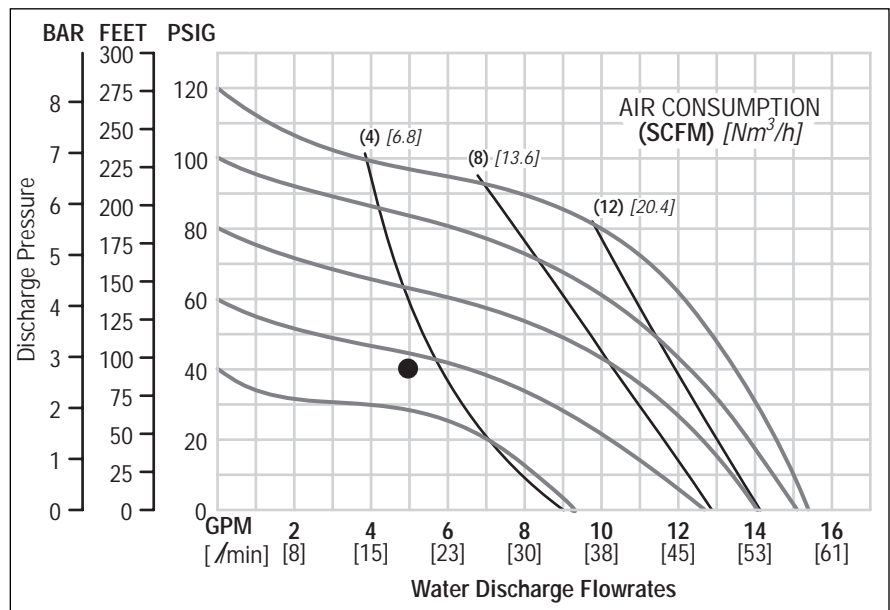

Flow rates indicated on chart were determined by pumping water.

For optimum life and performance, pumps should be specified so that daily operation parameters will fall in the center of the pump performance curve.

SECTION 5C

PERFORMANCE CURVES

MODEL P1 METAL TEFLON®-FITTED

Height 8 3/4" (222.3 mm)
 Width 8 5/2" (207.2 mm)
 Depth 8 1/8" (204.8 mm)
 Ship Weight Aluminum 13 lbs. (6 kg)
 Stainless Steel 20 lbs. (9.2 kg)
 Air Inlet 1/4" (6.35 mm)
 Inlet 1/2" (1.27 cm)
 Outlet 1/2" (1.27 cm)
 Suction Lift 16' Dry (4.88 m)
 31' Wet (9.45 m)

Displacement per

Stroke 0.025 gal. (.09 l)¹
 Max. Flow Rate 14.4 gpm (54.41 lpm)
 Max. Size Solids 1/16" (1.59 mm)

¹Displacement per stroke was calculated at 70 psig (4.8 Bar) air inlet pressure against a 30 psig (2 Bar) head pressure.

Example: To pump 5 gpm (18.9 lpm) against a discharge pressure head of 40 psig (2.7 Bar) requires 60 psig (4 Bar) and 3.5 scfm (5.92 Nm³/h) air consumption. (See dot on chart.)

Caution: Do not exceed 125 psig (8.6 Bar) air supply pressure.

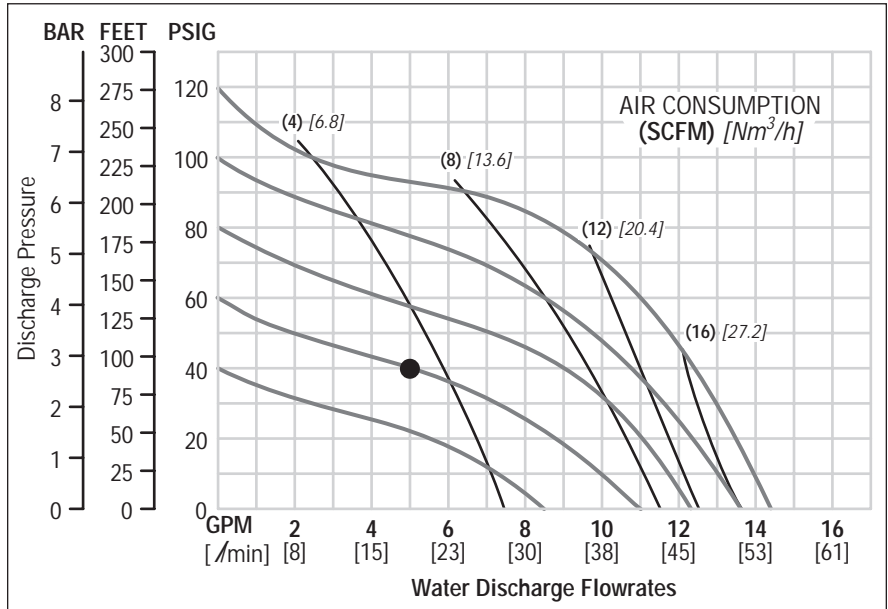

Flow rates indicated on chart were determined by pumping water.

For optimum life and performance, pumps should be specified so that daily operation parameters will fall in the center of the pump performance curve.

SECTION 6

SUCTION LIFT CURVES & DATA

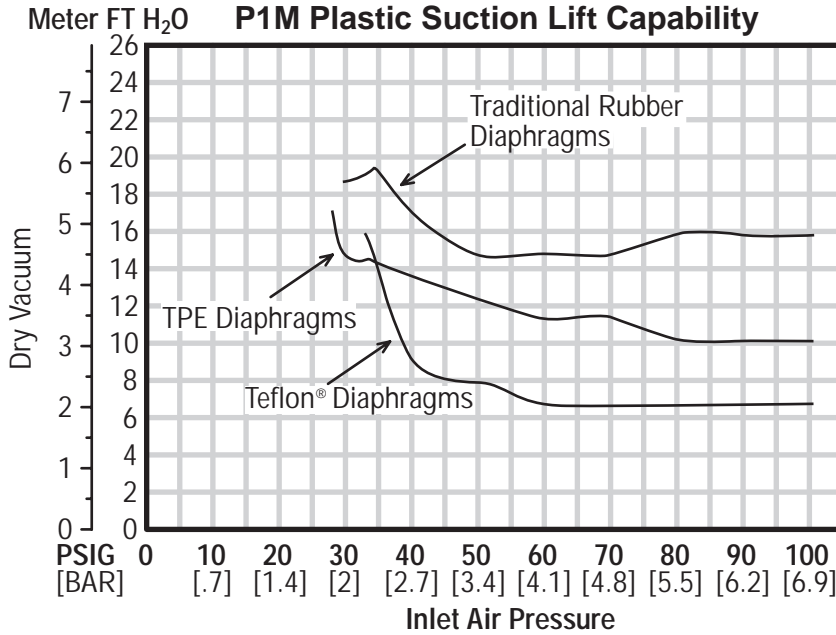

These vacuum numbers will double when a small amount of back pressure is placed on the discharge.

Suction lift curves are calibrated for pumps operating at 1,000' (305 m) above sea level. This chart is meant to be a guide only. There are many variables which can affect your pump's operating characteristics. The number of intake and discharge elbows,

viscosity of pumping fluid, elevation (atmospheric pressure) and pipe friction loss all affect the amount of suction lift your pump will attain.

SECTION 7

INSTALLATION

The P1 Pro-Flo™ model has a ½" (12.7 mm) inlet and ½" (12.7 mm) outlet and is designed for flows to 15.5 gpm (58.67 lpm). Refer to Section 5 for performance characteristics. The **P1 Metal** pump is manufactured with wetted parts of Aluminum, 316 Stainless Steel, and Hastelloy. The **P1** is available with a polypropylene or Acetal center section. A variety of diaphragms, valve balls, valve seats and O-rings are available to satisfy temperature, chemical compatibility, abrasion and flex concerns.

The suction pipe size should be at least ½" (12.7 mm) diameter or larger if highly viscous material is being pumped. The suction hose must be non-collapsible, reinforced type as the P1 is capable of pulling a high vacuum. Discharge piping should be at least ½" (12.7 mm); larger diameter can be used to reduce friction losses. It is critical that all fittings and connections are airtight or a reduction or loss of pump suction capability will result.

INSTALLATION: Months of careful planning, study, and selection efforts can result in unsatisfactory pump performance if installation details are left to chance.

Premature failure and long term dissatisfaction can be avoided if reasonable care is exercised throughout the installation process.

LOCATION: Noise, safety, and other logistical factors usually dictate where equipment will be situated on the production floor. Multiple installations with conflicting requirements can result in congestion of utility areas, leaving few choices for additional pumps.

Within the framework of these and other existing conditions, every pump should be located in such a way that five key factors are balanced against each other to maximum advantage.

ACCESS: First of all, the location should be accessible. If it's easy to reach the pump, maintenance personnel will have an easier time carrying out routine inspections and adjustments. Should major repairs become necessary, ease of access can play a key role in speeding the repair process and reducing total downtime.

AIR SUPPLY: Every pump location should have an air line large enough to supply the volume of air necessary to achieve the desired pumping rate (see Section 5). Use air pressure up to a maximum of 125 psi (8.6 Bar) depending on pumping requirements.

For best results, the pumps should use a 5 micron air filter, needle valve and regulator. The use of an air filter before the pump will ensure that the majority of any pipeline contaminants will be eliminated.

When operation is controlled by a solenoid valve in the air line, three-way valves should be used. This valve allows air trapped between the valve and the pump to bleed off which improves pump performance. Pumping volume can be determined by counting the number of strokes per minute and then multiplying the figure by the displacement per stroke.

MUFFLER: Sound levels are reduced below OSHA specifications using the standard Wilden muffler. Other mufflers can be used to further reduce sound levels, but they usually reduce

pump performance.

ELEVATION: Selecting a site that is well within the pump's dynamic lift capability will assure that loss-of-prime troubles will be eliminated. In addition, pump efficiency can be adversely affected if proper attention is not given to site location.

PIPING: Final determination of the pump site should not be made until the piping problems of each possible location have been evaluated. The impact of current and future installations should be considered ahead of time to make sure that inadvertent restrictions are not created for any remaining sites.

The best choice possible will be a site involving the shortest and straightest hook-up of suction and discharge piping. Unnecessary elbows, bends, and fittings should be avoided. Pipe sizes should be selected so as to keep friction losses within practical limits. All piping should be supported independently of the pump. In addition, the piping should be aligned so as to avoid placing stress on the pump fittings.

Flexible hose can be installed to aid in absorbing the forces created by the natural reciprocating action of the pump. If the pump is to be bolted down to a solid location, a mounting pad placed between the pump and the foundation will assist in minimizing pump vibration. Flexible connections between the pump and rigid piping will also assist in minimizing pump vibration. If quick-closing valves are installed at any point in the discharge system, or if pulsation within a system becomes a problem, a surge suppressor should be installed to protect the pump, piping and gauges from surges and water hammer.

If the pump is to be used in a self-priming application, be sure that all connections are airtight and that the suction lift is within the model's ability. Note: Materials of construction and elastomer material have an effect on suction lift parameters. Please refer to Section 6 for specifics.

The P1 can be installed in submersible applications only when both the wetted and non-wetted portions are compatible with the material being pumped. If the pump is to be used in a submersible application, a hose should be attached to the pump's air and pilot spool exhaust ports and piped above the liquid level. The exhaust area for the pilot spool is designed to be tapped with a ⅛" NPT fitting.

When pumps are installed in applications involving flooded suction or suction head pressures, a gate valve should be installed in the suction line to permit closing of the line for pump service.

Pumps in service with a positive suction head are most efficient when inlet pressure is limited to 7–10 psig (.48–.68 Bar). Premature diaphragm failure may occur if positive suction is 10 psig (.68 Bar) and higher.

THE MODEL P1 WILL PASS ⅛" (1.6 MM) SOLIDS. WHENEVER THE POSSIBILITY EXISTS THAT LARGER SOLID OBJECTS MAY BE SUCKED INTO THE PUMP, A STRAINER SHOULD BE USED ON THE SUCTION LINE.

CAUTION: DO NOT EXCEED 125 PSIG (8.6 BAR) AIR SUPPLY PRESSURE.

SUGGESTED INSTALLATION

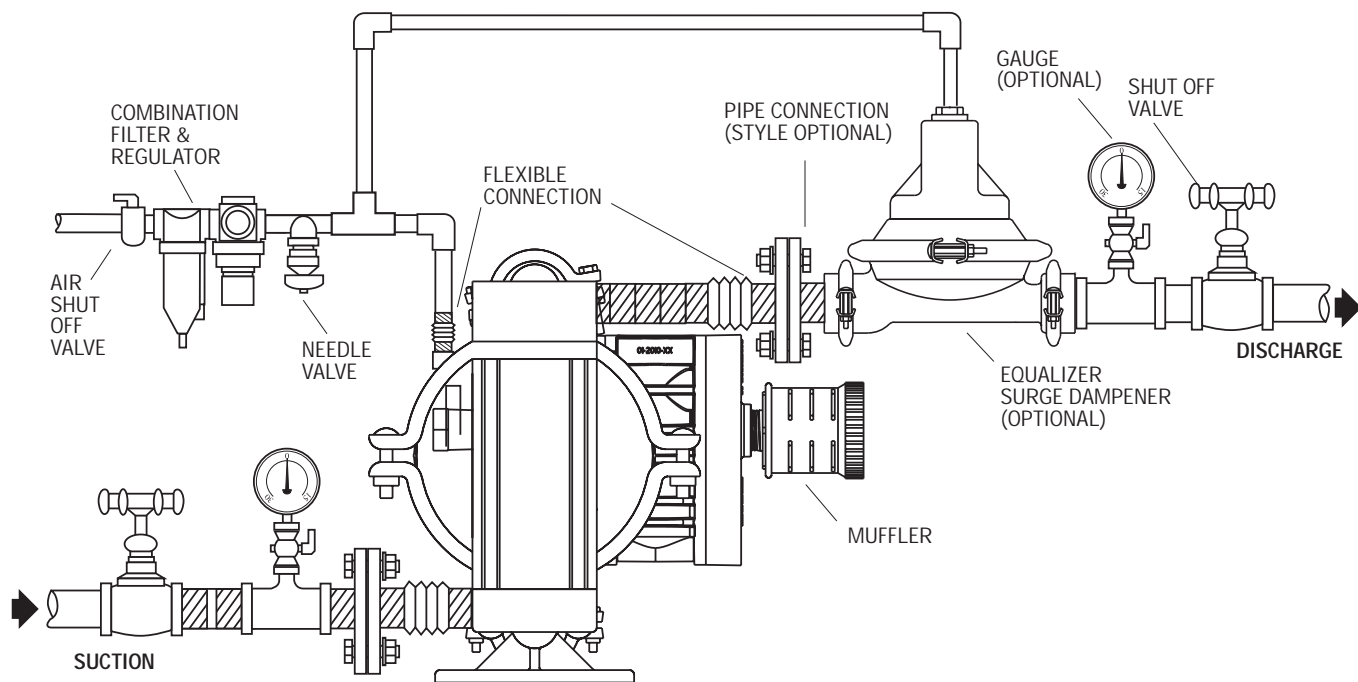

SECTION 7B

SUGGESTED OPERATION AND MAINTENANCE INSTRUCTIONS

OPERATION: Pump discharge rate can be controlled by limiting the volume and/or pressure of the air supply to the pump (preferred method). A regulator is used to regulate air pressure. A needle valve is used to regulate air volume. Pump discharge rate can also be controlled by throttling the pump discharge by partially closing a valve in the discharge line of the pump. This action increases friction loss which reduces flow rate. This is useful when the need exists to control the pump from a remote location. When the pump discharge pressure equals or exceeds the air supply pressure, the pump will stop; no bypass or pressure relief valve is needed, and pump damage will not occur. The pump has reached a "deadhead" situation and can be restarted by reducing the fluid discharge pressure or increasing the air inlet pressure. The Wilden P1 pump runs solely on compressed air and does not generate heat, therefore your process fluid temperature will not be affected.

RECORDS: When service is required, a record should be made of all necessary repairs and replacements. Over a period of time, such records can become a valuable tool for predicting and preventing future maintenance problems and unscheduled downtime. In addition, accurate records make it possible to identify pumps that are poorly suited to their applications.

MAINTENANCE AND INSPECTIONS: Since each application is unique, maintenance schedules may be different for every pump. Frequency of use, line pressure, viscosity and abrasiveness of process fluid all affect the parts life of a Wilden pump. Periodic inspections have been found to offer the best means for preventing unscheduled pump downtime. Personnel familiar with the pump's construction and service should be informed of any abnormalities that are detected during operation.

SECTION 7C

TROUBLESHOOTING

Pump will not run or runs slowly.

1. Ensure that the air inlet pressure is at least 5 psig (.35 Bar) above startup pressure and that the differential pressure (the difference between air inlet and liquid discharge pressures) is not less than 10 psig (.7 Bar).
2. Check air inlet filter for debris (see recommended installation).
3. Check for extreme air leakage (blow by) which would indicate worn seals/bores in the air valve, pilot spool, main shaft.
4. Disassemble pump and check for obstructions in the air passageways or objects which would obstruct the movement of internal parts.
5. Check for sticking ball check valves. If material being pumped is not compatible with pump elastomers, swelling may occur. Replace ball check valves and seals with proper elastomers. Also, as the check valve balls wear out, they become smaller and can become stuck in the seats. In this case, replace balls and seats.
6. Check for broken inner piston which will cause the air valve spool to be unable to shift.
7. Remove plug from pilot spool exhaust.

Pump runs but little or no product flows.

1. Check for pump cavitation; slow pump speed down to allow thick material to flow into liquid chambers.
2. Verify that vacuum required to lift liquid is not greater than the vapor pressure of the material being pumped (cavitation).

3. Check for sticking ball check valves. If material being pumped is not compatible with pump elastomers, swelling may occur. Replace ball check valves and seals with proper elastomers. Also, as the check valve balls wear out, they become smaller and can become stuck in the seats. In this case, replace balls and seats.

Pump air valve freezes.

1. Check for excessive moisture in compressed air. Either install a dryer or hot air generator for compressed air. Alternatively, a coalescing filter may be used to remove the water from the compressed air in some applications.

Air bubbles in pump discharge.

1. Check for ruptured diaphragm.
2. Check tightness of outer pistons (refer to Section 8C).
3. Check tightness of clamp bands and integrity of O-rings and seals, especially at intake manifold.
4. Ensure pipe connections are airtight.

Product comes out air exhaust.

1. Check for diaphragm rupture.
2. Check tightness of outer pistons to shaft.

SECTION 8A

MODEL P1 METAL

DIRECTIONS FOR DISASSEMBLY/REASSEMBLY

CAUTION: Before any maintenance or repair is attempted, the compressed air line to the pump should be disconnected and all air pressure allowed to bleed from the pump. Disconnect all intake, discharge, and air lines. Drain the pump by turning it upside down and allowing any fluid to flow into a suitable container. Be aware of any hazardous effects of contact with your process fluid.

The Wilden model P1 has a ½" (12.7 mm) inlet and outlet and is designed for flows up to 15.5 gpm (58.67 lpm). The single-piece center section, consisting of center block and air chambers, is molded of acetal or polypropylene. All fasteners and hardware are stainless steel and the air valve is manufactured of high-tech engineered plastic. All O-rings used in the pump are of a special material and shore hardness which should only be replaced with factory-supplied parts.

TOOLS REQUIRED:

¾" Box Wrench

⅞" Wrench

Adjustable Wrench

Vise equipped with soft jaws (such as plywood, plastic or other suitable material)

NOTE: The model used for these instructions incorporates rubber diaphragms, balls, and seats. Models with Teflon® diaphragms, balls and seats are the same except where noted.

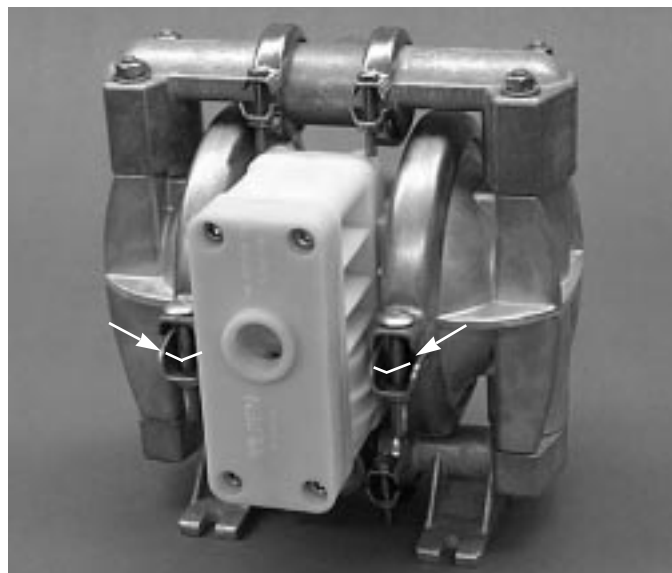

DISASSEMBLY:

Figure 1

Step 1.

Before starting disassembly, mark a line from each liquid chamber to its corresponding air chamber. This line will assist in proper alignment during reassembly. (Figure 1)

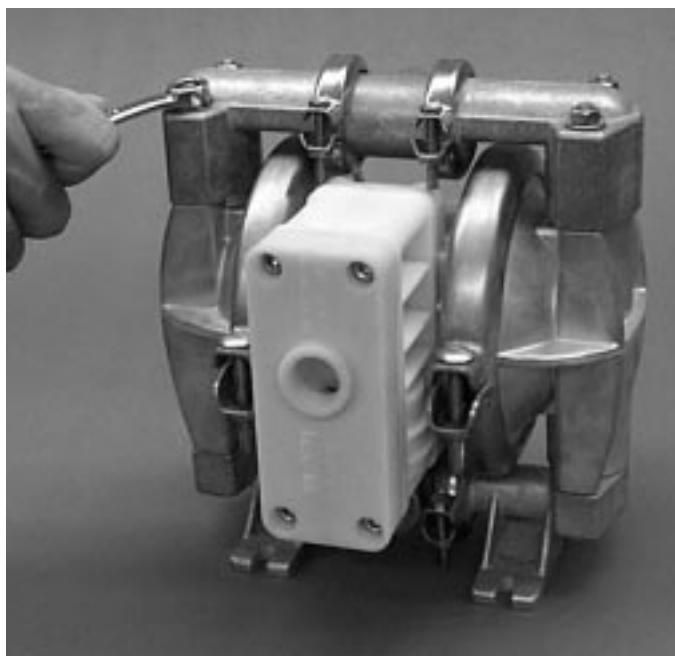

Step 2.

Figure 2

Utilizing the ¾" box wrench, start by removing the four long carriage bolts that hold the top and bottom manifolds to the center section. (Figure 2)

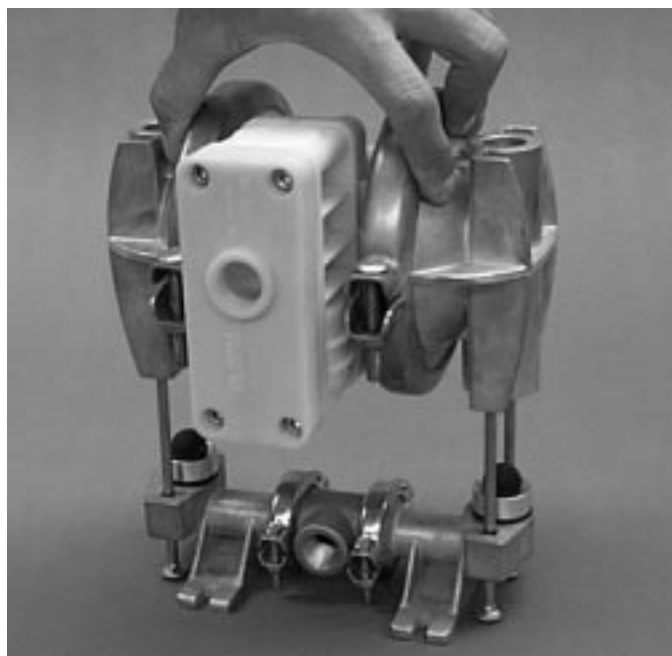

Step 3.

Figure 3

Remove the top manifold and lift the center section off the inlet manifold. (Figure 3)

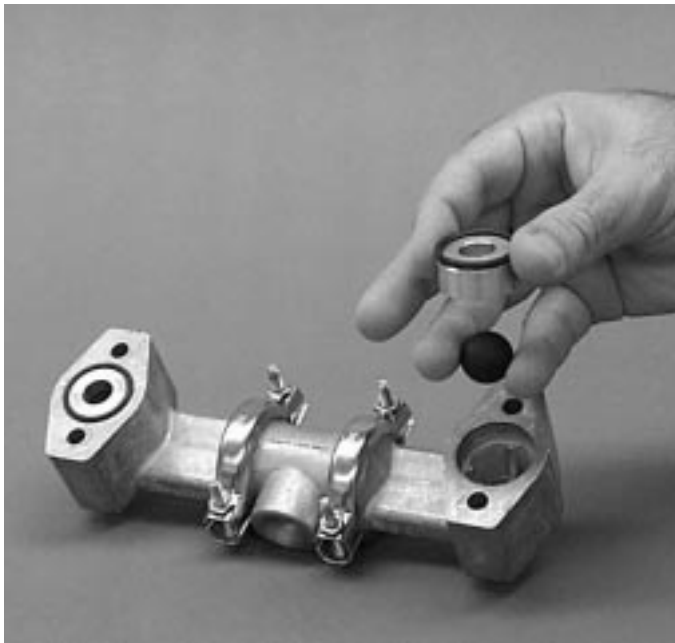

Step 4. *Figure 4*

Remove the discharge valve balls, seats and O-rings from the discharge manifold and inspect for nicks, gouges, chemical attack or abrasive wear. Replace worn parts with genuine Wilden parts for reliable performance. Teflon® O-rings should be replaced when reassembled. (Figure 4)

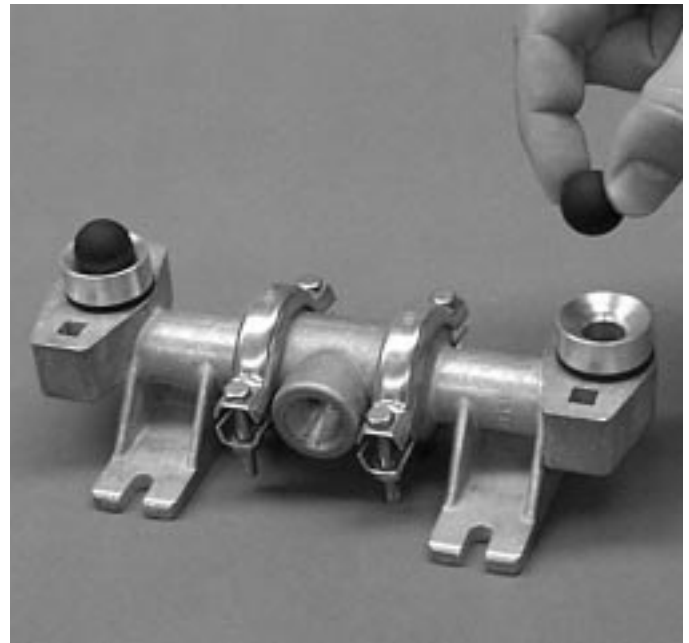

Step 5. *Figure 5*

Inspect the ball retainer, retainer O-ring, and valve ball from intake manifold. Check for nicks, gouges, chemical attack or abrasive wear. Replace worn parts with genuine Wilden parts for reliable performance. Teflon® O-rings should be replaced when reassembled. (Figure 5)



Step 6. *Figure 6*

Normally the inlet and discharge manifold should not be disassembled during regular pump maintenance. Should this be necessary, completely remove and disassemble manifold clamp bands utilizing a $\frac{3}{16}$ " wrench. (Figure 6)



Step 7. *Figure 7*

Inspect O-rings for wear or damage and replace if necessary. Teflon® O-rings should be replaced when reassembled. (Figure 7)

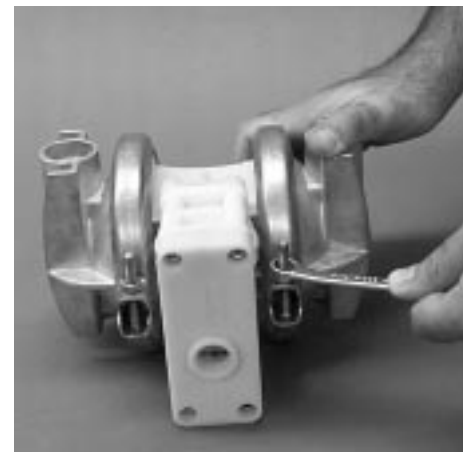

Step 8. *Figure 8*

Use a $\frac{3}{8}$ " wrench to remove one set of clamp bands that secure one liquid chamber to the one-piece center section. (Figure 8)

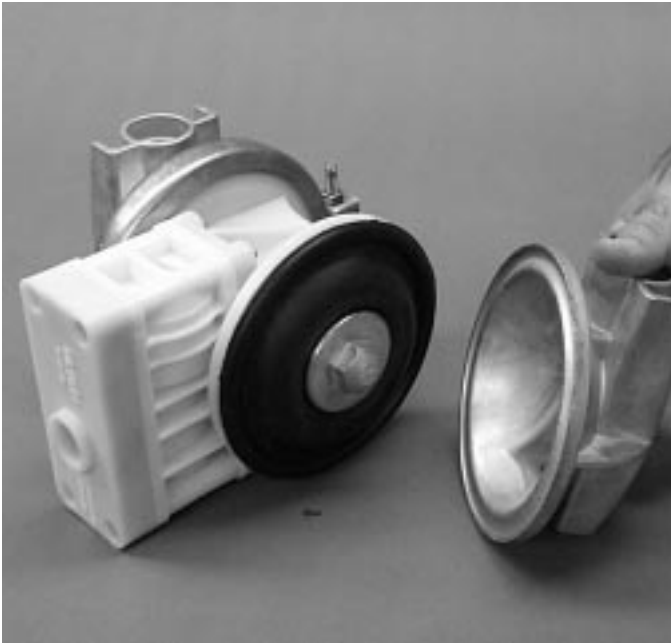

Step 9. *Figure 9*

Lift the liquid chamber away from the center section to expose the diaphragm and outer piston. (*Figure 9*)



Step 10. *Figure 10*

Using an adjustable wrench, or by rotating the diaphragm by hand, remove the diaphragm assembly from the center section. (*Figure 10*)



Step 11A. *Figure 11A*

NOTE: Due to varying torque values, one of the following two situations may occur: 1) The outer piston, diaphragm and inner piston remain attached to the shaft and the entire assembly can be removed from the center section. (*Figure 11A*)

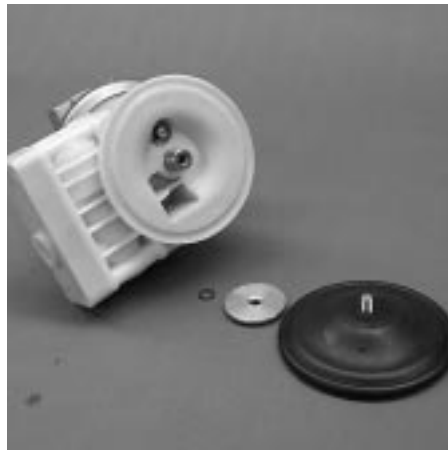

Step 11B. *Figure 11B*

2) The outer piston, diaphragm, inner piston, and disc spring separate from the shaft which remains connected to the opposite side diaphragm assembly (*Figure 11B*). Teflon®-fitted pumps come standard with back-up diaphragms (not shown).



Step 12. *Figure 12*

To remove the diaphragm assembly from the shaft, secure shaft with soft jaws (a vise fitted with plywood or other suitable material) to ensure shaft is not nicked, scratched, or gouged. Using an adjustable wrench, remove diaphragm assembly from shaft. Inspect all parts for wear and replace with genuine Wilden parts if necessary. (*Figure 12*)

SECTION 8B

PRO-FLO™ AIR VALVE/CENTER SECTION DISASSEMBLY, CLEANING, INSPECTION

AIR VALVE DISASSEMBLY:

CAUTION: Before any maintenance or repair is attempted, the compressed air line to the pump should be disconnected and all air pressure allowed to bleed from the pump. Disconnect all intake, discharge, and air lines. Drain the pump by turning it upside down and allowing any fluid to flow into a suitable container. Be aware of hazardous effects of contact with your process fluid.

The Wilden Metal P1 utilizes a revolutionary Pro-Flo™ air distribution system. A ½" (1.27 cm) air inlet connects the air supply to the center section. Proprietary composite seals reduce the coefficient of friction and allow the P1 to run lube-free. Constructed of Acetal or Polypropylene, the Pro-Flo™ air distribution system is designed to perform in on/off, non-freezing, non-stalling, tough duty applications.

TOOLS REQUIRED:

- ⅜" Hex Head Wrench
- ⅞" Hex Head Wrench
- Snap Ring Pliers
- O-Ring Pick



Step 1.

Figure 1

Loosen the air valve bolts utilizing a ⅜" hex head wrench. (Figure 1)

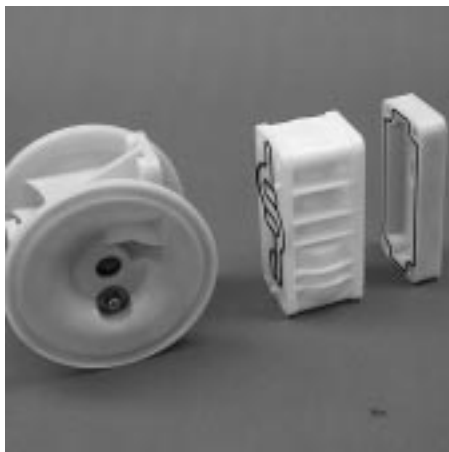

Step 2.

Figure 2

Remove muffer plate and air valve bolts from air valve assembly (Figure 2) exposing muffer gasket for inspection. Replace if necessary.



Step 3.

Figure 3

Lift away air valve assembly and remove air valve gasket for inspection (Figure 3). Replace if necessary.



Step 4.

Figure 4

Remove air valve end cap to expose air valve spool by simply lifting up on end cap once air valve bolts are removed. (Figure 4).



Step 5. *Figure 5*

Remove air valve spool from air valve body by threading one air valve bolt into the end of the spool and gently sliding the spool out of the air valve body (*Figure 5*). Inspect seals for signs of wear and replace entire assembly if necessary. Use caution when handling air valve spool to prevent damaging seals.

NOTE: Seals should not be removed from assembly. Seals are not sold separately.



Step 6. *Figure 6*

Remove pilot spool retaining snap ring on both sides of center section with snap ring pliers (*Figure 6*).



Step 7. *Figure 7*

Remove pilot spool sleeve from center section (*Figure 7*).



Step 8. *Figure 8*

With O-ring pick, gently remove pilot spool retaining O-ring (*Figure 8*). Replace if necessary. Gently remove pilot spool from sleeve and inspect spool and seals for nicks, gouges or other signs of wear. Replace pilot sleeve assembly or sleeve O-rings if necessary.

NOTE: Seals should not be removed from pilot spool. Seals are not sold separately.



Step 9. *Figure 9*

Check center section Glyd™ rings for signs of wear. If necessary, remove Glyd™ rings with O-ring pick and replace. (*Figure 9*)

SECTION 8C

REASSEMBLY HINTS & TIPS

ASSEMBLY:

Upon performing applicable maintenance to the air distribution system, the pump can now be reassembled. Please refer to the disassembly instructions for photos and parts placement. To reassemble the pump, follow the disassembly instructions in reverse order. The air distribution system needs to be assembled first, then the diaphragms and finally the wetted path. Please find the applicable torque specifications on this page. The following tips will assist in the assembly process.

- Clean the inside of the center section shaft bore to ensure no damage is done to new seals.
- Stainless bolts should be lubed to reduce the possibility of seizing during tightening.
- Level the water chamber side of the intake/discharge manifold to ensure a proper sealing surface. This is most easily accomplished by placing them on a flat surface prior to tightening their clamp bands to the desired torque (see this page for torque specs).
- Be sure to tighten outer pistons simultaneously on Teflon®-fitted pumps to ensure proper torque values.
- Ensure proper mating of liquid chambers to manifolds prior to tightening vertical bolts. Overhang should be equal on both sides.
- Apply a small amount of Loctite 242 to the shaft interval threads before the diaphragm assembly.
- Concave side of disc spring in diaphragm assembly faces **toward** shaft.

MAXIMUM TORQUE SPECIFICATIONS

Description of Part	Metal Pumps
Air Valve, Pro-Flo™	20 in.-lbs. [3.3 m-N]
Outer Piston	75 in.-lbs. [8.7 m-N]
Small Clamp Band	15 in.-lbs. [1.7 m-N]
Large Clamp Band (Rubber-Fitted)	65 in.-lbs. [7.4 m-N]
Large Clamp Band (Teflon®-Fitted)	85 in.-lbs. [9.6 m-N]
Vertical Bolts	125 in.-lbs. [14.1 m-N]
Air Inlet, Reducer Bushing	10 ft.-lbs. [13.6 m-N]

EXPLODED VIEW/PARTS LISTING

P1

METAL
AIR-
CONTROLLED
RUBBER/TPE-
FITTED

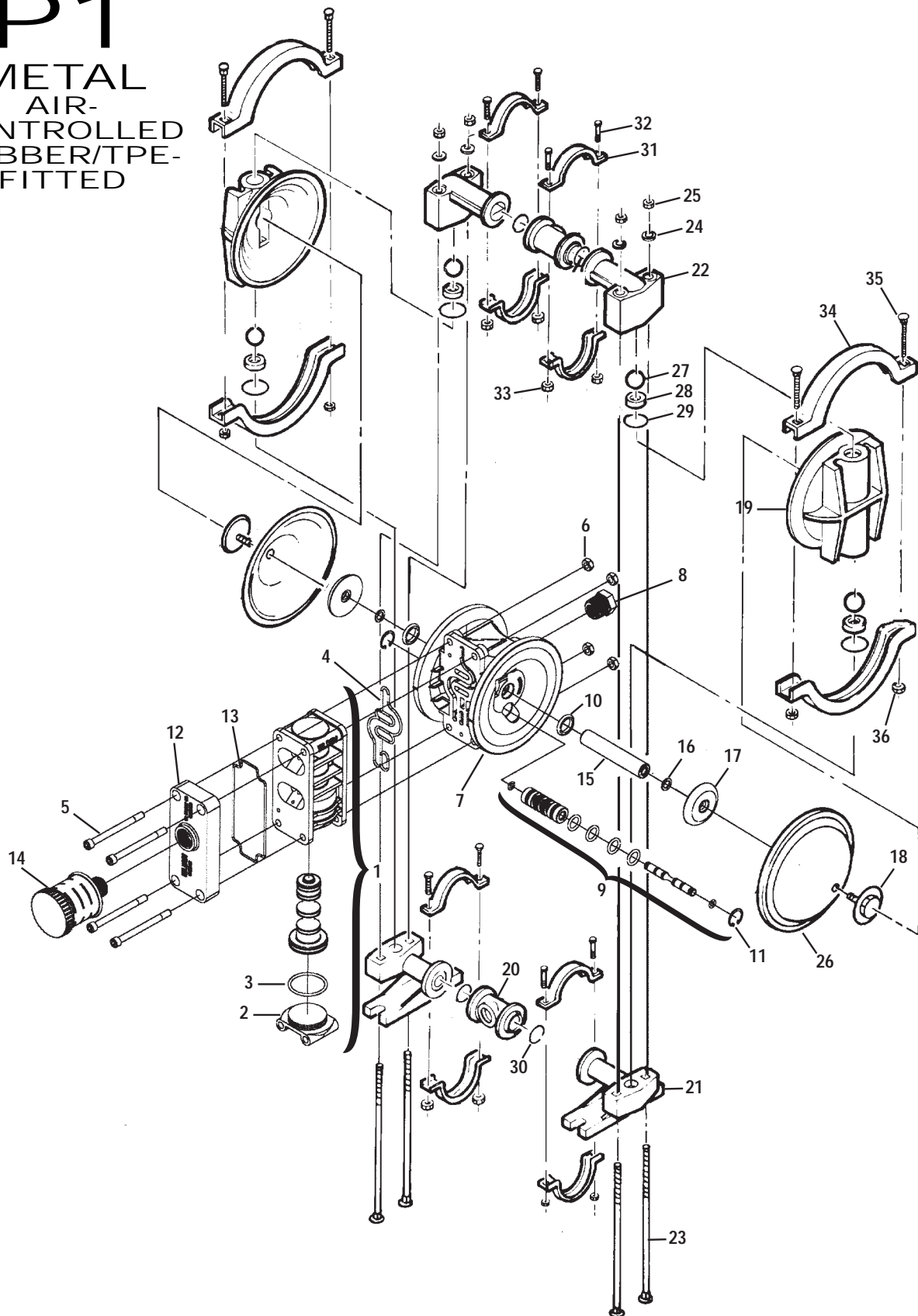

MODEL P1 METAL RUBBER-FITTED

Item	Part Description	Qty. Per Pump	P1/	P1/	P1/	P1/
			APPP	SPPP	HPPP	SPPP-070
			P/N	P/N	P/N	P/N
1	Pro-Flo™ Air Valve Assembly¹	1	01-2010-20	01-2010-20	01-2010-20	01-2010-20
2	End Cap	1	01-2332-20	01-2332-20	01-2332-20	01-2332-20
3	O-Ring, End Cap	1	01-2395-52	01-2395-52	01-2395-52	01-2395-52
4	Gasket, Air Valve	1	01-2615-52	01-2615-52	01-2615-52	01-2615-52
5	Screw, HSHC, Air Valve 1/4"-20	4	01-6001-03	01-6001-03	01-6001-03	01-6001-03
6	Nut, Hex, 1/4"-20	4	04-6400-03	04-6400-03	04-6400-03	04-6400-03
7	Center Section Assembly	1	01-3140-20	01-3140-20	01-3140-20	01-3140-20
8	Bushing, Reducer	1	01-6950-20	01-6950-20	01-6950-20	01-6950-20
9	Removable Pilot Sleeve Assembly	1	01-3880-99	01-3880-99	01-3880-99	01-3880-99
10	Glyd™ Ring II	2	01-3220-55	01-3220-55	01-3220-55	01-3220-55
11	Retaining Ring	2	00-2650-03	00-2650-03	00-2650-03	00-2650-03
12	Muffler Plate	1	01-3181-20	01-3181-20	01-3181-20	01-3181-20
13	Gasket, Muffler Plate	1	01-3505-52	01-3505-52	01-3505-52	01-3505-52
14	Muffler	1	02-3510-99	02-3510-99	02-3510-99	02-3510-99
15	Shaft, Pro-Flo™	1	01-3810-09	01-3810-09	01-3810-09	01-3810-09
16	Disc Spring	2	01-6802-08	01-6802-08	01-6802-08	01-6802-08
17	Inner Piston	2	01-3711-08	01-3711-08	01-3711-08	01-3711-08
18	Outer Piston	2	01-4570-01	01-4570-03	01-4570-04	01-4570-03
19	Liquid Chamber	2	01-5000-01	01-5000-03	01-5000-04	01-5000-03
20	Manifold Tee Section	2	01-5160-01	01-5160-03	01-5160-04	01-5160-03-70
21	Inlet Manifold Elbow	2	01-5220-01	01-5220-03	01-5220-04-	01-5220-03
22	Discharge Manifold Elbow	2	01-5230-01	01-5230-03	01-5230-04	01-5230-03
23	Screw, SHCS (Chamber Bolt)	4	01-6080-03	01-6080-03	01-6080-03	01-6080-03
24	Vertical Bolt Washer	4	01-6730-03	01-6730-03	01-6730-03	01-6730-03
25	Vertical Bolt Nut	4	04-6400-03	04-6400-03	04-6400-03	04-6400-03
26	Diaphragm	2	*	*	*	01-1010-56
27	Valve Ball	4	*	*	*	01-1080-56
28	Valve Seat	4	*	*	*	01-1120-03
29	Valve Seat O-Ring	4	*	*	*	01-1200-56
30	Manifold O-Ring	4	*	*	*	01-1300-56
31	Small Clamp Band	8	01-7100-03	01-7100-03	01-7100-03	01-7100-03
32	Small Clamp Band Bolt	8	01-6101-03	01-6101-03	01-6101-03	01-6101-03
33	Small Clamp Band Nut	8	01-6400-03	01-6400-03	01-6400-03	01-6400-03
34	Large Clamp Band	4	01-7300-03	01-7300-03	01-7300-03	01-7300-03
35	Large Clamp Band Bolt	4	01-6070-03	01-6070-03	01-6070-03	01-6070-03
36	Large Clamp Band Nut	4	04-6400-03	04-6400-03	04-6400-03	04-6650-03-70

¹Air Valve Assembly includes items 2 and 3.

*Refer to corresponding elastomer chart in Section 10.

-070 Specialty Code = Saniflo™

All boldface items are primary wear parts.

EXPLODED VIEW/PARTS LISTING

P1

METAL
AIR-
CONTROLLED
TEFLON®-
FITTED

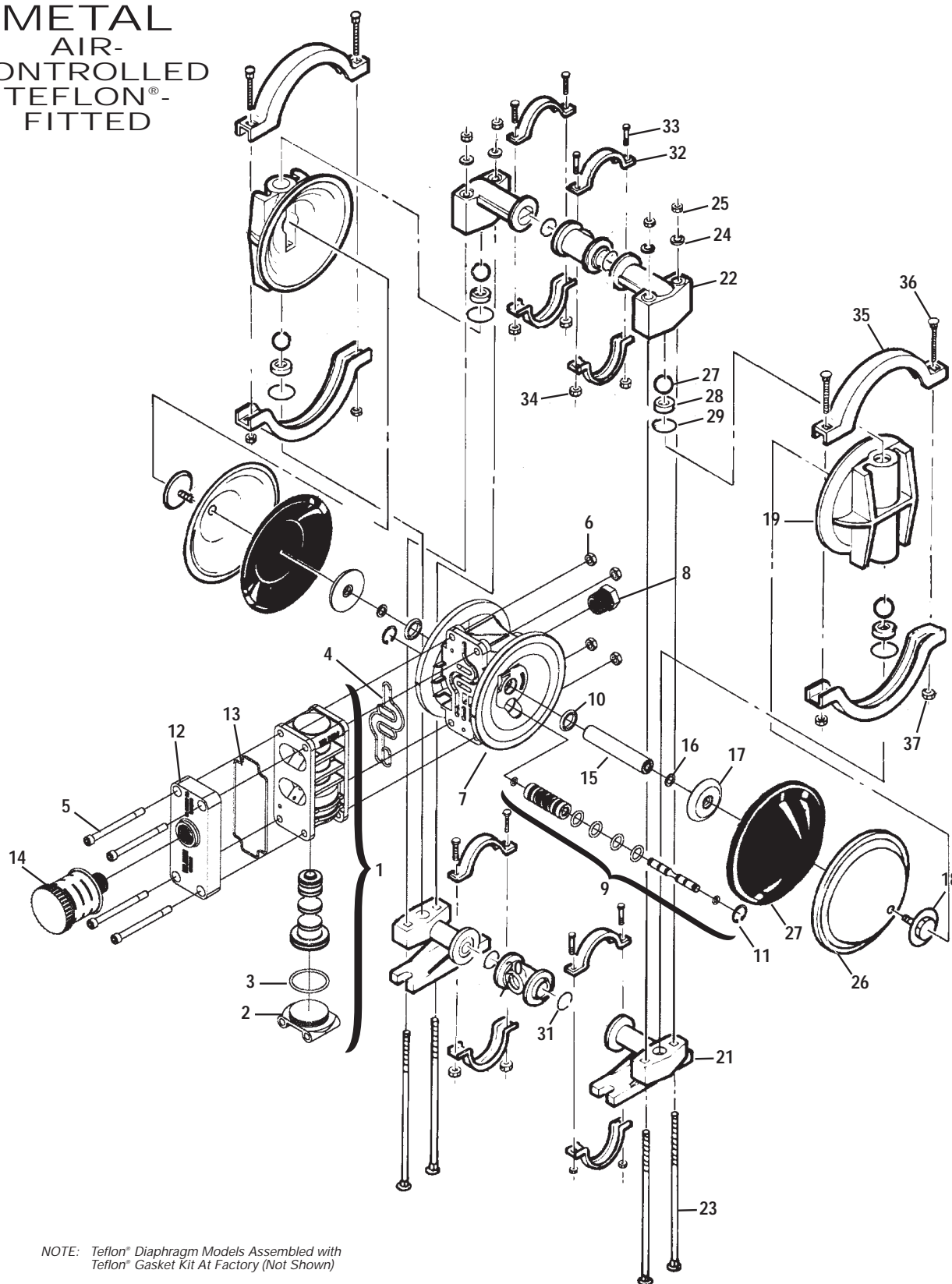

NOTE: Teflon® Diaphragm Models Assembled with
Teflon® Gasket Kit At Factory (Not Shown)

MODEL P1 METAL TEFLON®-FITTED

Item	Part Description	Qty. Per Pump	P1/ APPP	P1/ SPPP	P1/ HPPP	P1/ SPPP-070
			P/N	P/N	P/N	P/N
1	Pro-Flo™ Air Valve Assembly¹	1	01-2010-20	01-2010-20	01-2010-20	01-2010-20
2	End Cap	1	01-2332-20	01-2332-20	01-2332-20	01-2332-20
3	O-Ring, End Cap	1	01-2395-52	01-2395-52	01-2395-52	01-2395-52
4	Gasket, Air Valve	1	01-2615-52	01-2615-52	01-2615-52	01-2615-52
5	Screw, HSHC, Air Valve 1/4"-20	4	01-6001-03	01-6001-03	01-6001-03	01-6001-03
6	Nut, Hex, 1/2"-20	4	04-6400-03	04-6400-03	04-6400-03	04-6400-03
7	Center Section Assembly	1	01-3140-20	01-3140-20	01-3140-20	01-3140-20
8	Bushing, Reducer	1	01-6950-20	01-6950-20	01-6950-20	01-6950-20
9	Removable Pilot Sleeve Assembly	1	01-3880-99	01-3880-99	01-3880-99	01-3880-99
10	Glyd™ Ring II	2	01-3220-55	01-3220-55	01-3220-55	01-3220-55
11	Retaining Ring	2	00-2650-03	00-2650-03	00-2650-03	00-2650-03
12	Muffler Plate	1	01-3181-20	01-3181-20	01-3181-20	01-3181-20
13	Gasket, Muffler Plate	1	01-3505-52	01-3505-52	01-3505-52	01-3505-52
14	Muffler	1	02-3510-99	02-3510-99	02-3510-99	01-3510-99
15	Shaft, Pro-Flo™	1	01-3810-09	01-3810-09	01-3810-09	01-3810-09
16	Disc Spring (Belleville Washer)	2	01-6802-08	01-6802-08	01-6802-08	01-6802-08
17	Inner Piston	2	01-3711-08	01-3711-08	01-3711-08	01-3711-08
18	Outer Piston	2	01-4570-01	01-4570-03	01-4570-04	01-4570-03
19	Liquid Chamber	2	01-5000-01	01-5000-03	01-5000-04	01-5000-03
20	Manifold Tee Section	2	01-5160-01	01-5160-03	01-5160-04	01-5160-03-70
21	Inlet Manifold Elbow	2	01-5220-01	01-5220-03	01-5220-04-	01-5220-03
22	Discharge Manifold Elbow	2	01-5230-01	01-5230-03	01-5230-04	01-5230-03
23	Screw, SHCS (Chamber Bolt)	4	01-6080-03	01-6080-03	01-6080-03	01-6080-03
24	Vertical Bolt Washer	4	01-6730-03	01-6730-03	01-6730-03	01-6730-03
25	Vertical Bolt Nut	4	04-6400-03	04-6400-03	04-6400-03	04-6400-03
26	PTFE Primary Diaphragm	2	01-1010-55	01-1010-55	01-1010-55	01-1010-55
27	Neoprene Backup Diaphragm	2	01-1060-51	01-1060-51	01-1060-51	01-1060-51
28	Valve Ball	4	01-1080-55	01-1080-55	01-1080-55	01-1080-55
29	Valve Seat	4	01-1120-01	01-1120-03	01-1120-04	01-1120-03
30	Valve Seat O-Ring	4	01-1200-55	01-1200-55	01-1200-55	01-1200-55
31	Manifold O-Ring	4	01-1300-55	01-1300-55	01-1300-55	01-1300-55
32	Small Clamp Band	8	01-7100-03	01-7100-03	01-7100-03	01-7100-03
33	Small Clamp Band Bolt	8	01-6101-03	01-6101-03	01-6101-03	01-6101-03
34	Small Clamp Band Nut	8	01-6400-03	01-6400-03	01-6400-03	01-6400-03
35	Large Clamp Band	4	01-7300-03	01-7300-03	01-7300-03	01-7300-03
36	Large Clamp Band Bolt	4	01-6070-03	01-6070-03	01-6070-03	01-6070-03
37	Large Clamp Band Nut	4	04-6400-03	04-6400-03	04-6400-03	04-6650-03-70

¹Air Valve Assembly includes items 2 and 3.

*Refer to corresponding elastomer chart in Section 10.

-070 Specialty Code = Saniflo[®]DA

All boldface items are primary wear parts.

SECTION 10A

ELASTOMER OPTIONS

ELASTOMER OPTIONS FOR MODEL P1 METAL PUMPS

Material	Diaphragm P/N	Valve Ball P/N	Valve Seat P/N	Valve Seat O-Ring P/N	Manifold O-Ring P/N
Polyurethane	01-1010-50	01-1080-50	N/A	01-1200-50	01-1300-50
Buna-N®	01-1010-52	01-1080-52	N/A	01-1200-52	01-1300-52
Viton®	01-1010-53	01-1080-53	01-1120-53*	N/A	N/A
Wil-Flex™	01-1010-58	01-1080-58	N/A	01-1200-58	01-1300-58
Saniflex™	01-1010-56	01-1080-56	N/A	01-1200-56	01-1300-56
Teflon® PTFE	01-1010-55	01-1080-55	N/A	01-1200-55	01-1300-55
Stainless Steel	N/A	N/A	01-1120-03	N/A	N/A
Aluminum	N/A	N/A	01-1120-01	N/A	N/A
Hastelloy	N/A	N/A	01-1120-04	N/A	N/A

*Use in conjunction with seat spacer (P/N 01-1120-21-500).

MAINTENANCE RECORD

DATE	SERVICE RENDERED	SERVICED BY

ENGINEERED A REVOLUTION

“Revolutionizing the way you solve your toughest pumping problems”



Plastic

- Polypropylene
- Carbon-Filled Acetal
- PVDF
- Teflon® PTFE
- Teflon® PFA



Metal

- Aluminum
- 316 S.S.
- Cast Iron
- Hastelloy



SANIFLO
SANITARY PUMP TECHNOLOGY

FDA USDA 3A

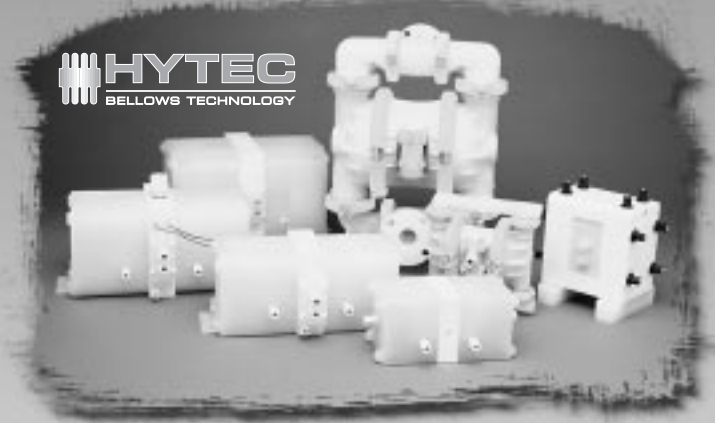

HYTEC
BELLOWS TECHNOLOGY

ULTRAPURE
TEFLON PROCESS PUMPS

- Teflon® PFA
- Teflon® PTFE



Accessories

- SPCI
- Wil-Gard
- FCSI
- Equalizers
- Drum Pump Kits
- APV



WILDEN

AIR OPERATED DOUBLE DIAPHRAGM PUMPS

22069 Van Buren St., Grand Terrace, CA 92313-5607
Telephone (909) 422-1730 • Fax (909) 783-3440
www.wildenpump.com

A **DOVER** RESOURCES COMPANY

Your local authorized distributor:

