

---

# OMAC



## lobe pumps



AUT. N° 810

# STANDARD VERSION

Standard Lobe Pumps in AISI 316 stainless steel are assembled on a cast iron gear box which has a protective coating in epoxy paint finish. The chamber separating the rotor case and gear box enables the fitting of balanced compact reversible mechanical seals, avoiding the contamination between the pumped fluid and the gearbox lubricant. The base of the gearbox is designed to make installation easier for connecting into horizontal and vertical pipelines. The OMAC Lobe Pump is modular in design allowing the main parts such as the rotor and seals, to be changed quickly and easily.

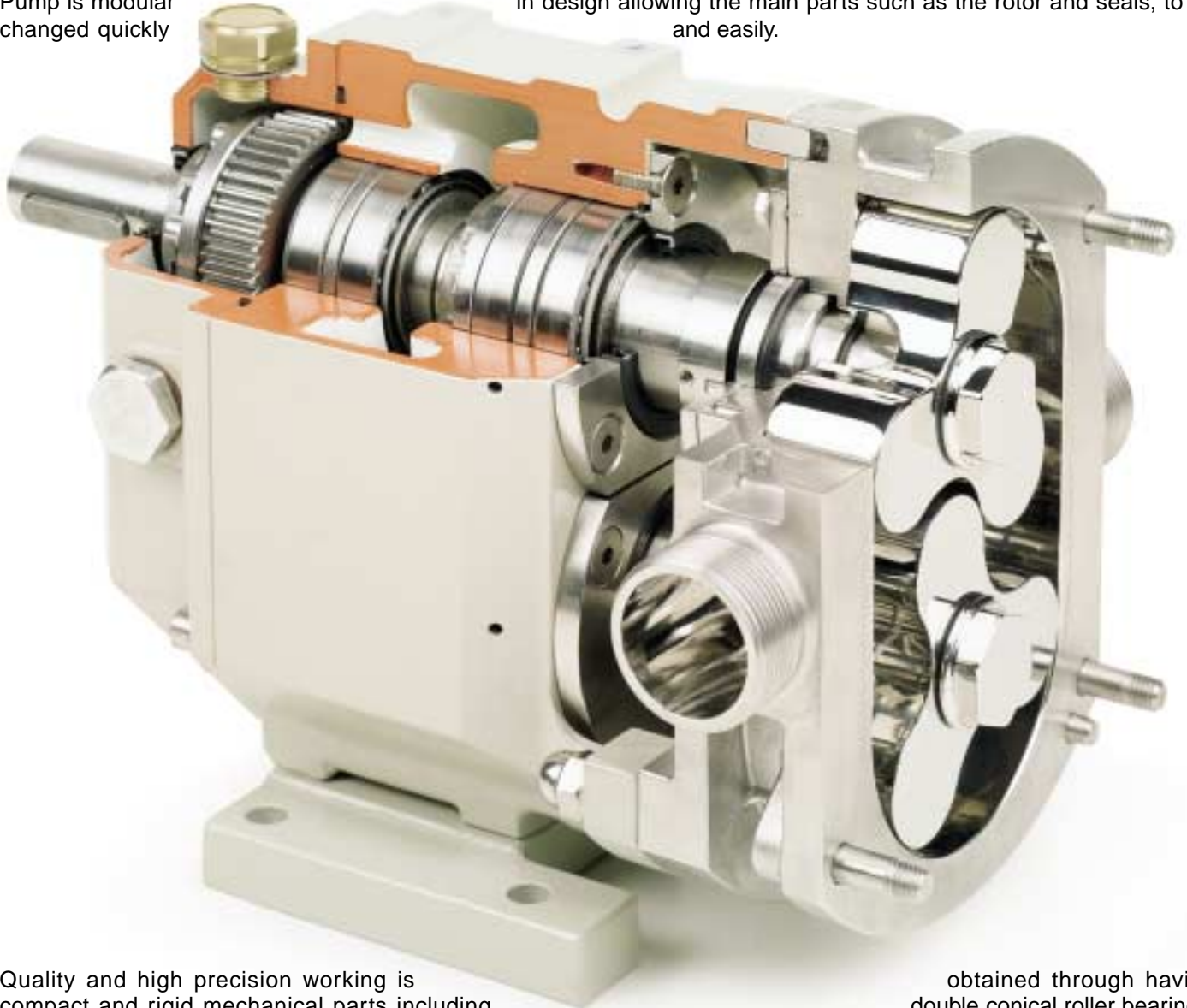

Quality and high precision working is compact and rigid mechanical parts including shafts and oversized gears running in an oil bath within the gearbox. This is to obtain smaller tolerances as the rotors do not have any contact points. This ensures a good pump performance and reliability is obtained.

In the Rotary Lobe pumps the rotors rotate in an opposite direction without contact with each other. Thanks to this characteristic the metal parts do not wear and contaminate the product and there is also no damage to the product. The Lobe pumps are also suitable for handling abrasive products.

The transmission movement from the motor drive shaft to the driven shaft is made by double high precision gears. The timing device is simple and accessible - one gear is fixed and the other gear mounted on the bush is adjustable.

obtained through having double conical roller bearings, gearbox.

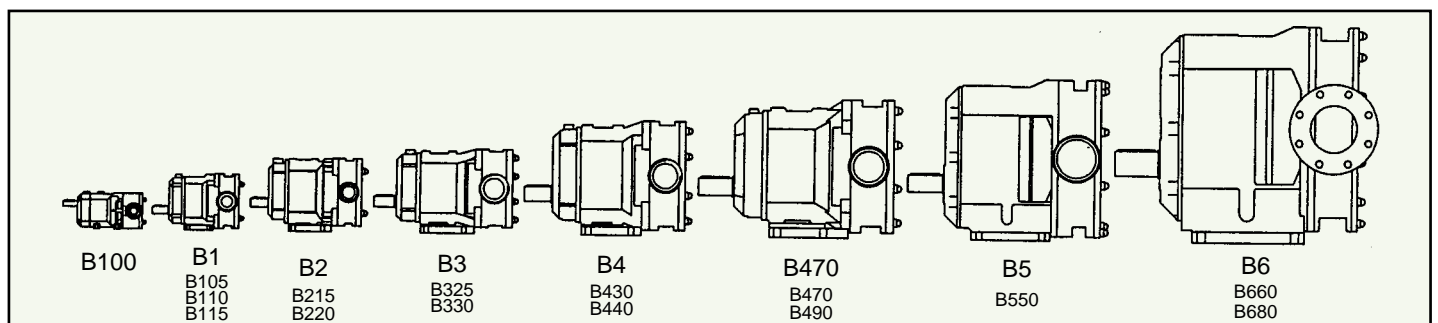

# SPECIAL VERSIONS

## ASEPTIC VERSION



contaminated by bacteria or micro-organisms during transfer.

All standard models can be produced in Aseptic versions with sterile, steam or liquid barriers on the end cover, shaft seals and suction/discharge ports. This type of pump is used in the food and pharmaceutical sterilised product packaging areas where it is important that the product is not

## ENLARGED SUCTION INLET



a vertical axis in order to allow the entry of the product under gravity directly beneath the hopper.

The B115, B220, B330, B440 Models can be supplied with enlarged rectangular suction inlets allowing highly viscous products such as semi-solid pastes or mixtures containing semi-solid pieces to be pumped. In these cases the pump is generally positioned with the port on

## HEATED JACKET BODY



If it is necessary to keep the pumped fluid at a constant temperature a heated jacket body is available for all the pumps except the B100. This allows the circulation of heating or cooling liquid. Typical examples are melted fats, butter and margarine, chocolate and glucose.

## HEATED JACKET FRONT COVER



The front cover can be made suitable for heating or cooling the pump and its own or with heated jacket on the body.

## FLUSHED SEALS



When the pump is transferring products that may crystallise or leave solid deposits, the mechanical seals supplied have to be cleaned by flushing water or a compatible liquid at low pressure. This flushing arrangement can also be used to dissipate heat or to avoid dry running. There is a fixed chamber around the standard seal with the UM seal for sealing the flushing liquid.

Should the flushing liquid be aggressive, dangerous or a pollutant, and the pressure is higher than the working or pumped fluid, it is possible to fit a double flushed mechanical seal. In this case the second seal is necessary to avoid the flushing liquid leaking.

## PUMPS IN SPECIAL MATERIALS



versions with all parts in contact with the product in Hastelloy, Titanium or Monel, a mix can also be produced, e.g. moving parts in Titanium and stationery parts in Hastelloy.

OMAC can produce Lobe pumps for transferring all kinds of aggressive products. The B100 and B330 Models can be manufactured in mixed versions, i.e. shafts and rotors in Titanium, Hastelloy or Monel, with the pump/cover body in Thermoplastic Resin. For larger sizes or high working pressures there are other

## PUMPS WITH HYDRAULIC MOTOR



Specifically designed for road tanker duties, the B325 and B330 can be supplied with flanged gear cover direct coupled to hydraulic motor. These pumps can be supplied bare shaft or complete with hydraulic motor, power station and control system.



## PRESSURE RELIEF VALVE SYSTEMS



INTEGRAL PRESSURE RELIEF VALVE

The pumps can be supplied on request with hygienic by-pass or pressure relief valves. This device protects the pump from pressure peaks or restrictions in the discharge and assures excess liquid deviation during CIP and SIP. The relief valve can be manually selected as a flow regulator in order to pass product allowing the pump to run continuously. This valve can be incorporated in the end cover that



EXTERNAL PRESSURE RELIEF VALVE

replaces the standard cover, providing a pressure relief valve loop from discharge to the suction area; alternatively it can be incorporated in the discharge pipework, relieving excess pressure by by-passing product through a loop back to the suction side. The integral relief valve is suitable for CIP process line and functions for either direction of flow: it is available on Models B105 to B440. On all models it is possible to assemble an external pressure relief valve in order to recycle the whole pumped product, this valve is especially suitable for frequently operations and for volatile, heat or shear sensitive product. For both of the valves a manual, pneumatic or automatic operation is available.

## MOUNTING AND DRIVES



MAC Rotary Lobe Pumps can be supplied either bareshaft or complete with baseplate in either stainless steel (AISI 304) or painted iron, couplings, guard and electric drives. It is also possible to have baseplates suitable for mounting the pump on when it has vertical connections. Trolleys and overhead bases and such accessories as adjustable feet and stainless steel shrouds covering the motors can also be supplied as to build pumping sets which exactly satisfy customers' requirements. Power transmission can be variable speed via a mechanical, hydraulic or belt adjustable speed unit; alternatively it can be fixed speed via reduction geared motor. For controlling the pumps the options are various and these include on off reversing switch, inverter integrated into the motor, IP65 inverter, electric control panel with IP21 inverter for remote control signal.





## CHECKS AND TESTS

All testing of the pumps during different working phases is according to ISO 9000-9001.

The final test on each pump is with water and is tested at maximum permitted conditions with particular attention to the performance. It is possible to issue a Test Certificate if required.



## MATERIALS OF CONSTRUCTION

All shafts are manufactured from AISI 316 or Duplex sheet stainless steel. The rotors are manufactured from either high quality AISI 316L extruded shaped bar or in special stainless steel anti-seizure alloy (Acteon). The pump body is also manufactured from AISI 316L stainless steel and except for the B100 pump type, which is made from a sheet, all the other pumps are made from the lost wax casting method. It is possible to have certificates of all raw materials for traceability purposes.

## ROTORS



Dependant on the type of use the rotors can be made as: standard stainless steel tri-lobes, stainless steel bi-lobes, acteon dual wing rotary piston, gears for Models B100 and B105. The stainless steel tri-lobe rotors (5 lobes for Models B100 and B105) and stainless steel bi-lobes can all be covered with rubber in different compositions. The rotors are inter-changeable and should they need to be replaced it is possible to assemble the same type or different types of rotors, irrespective of their shape or the clearances. After replacing the lobes it will be necessary to control or reset the final tolerances (see Use and Maintenance Manual), and to make the necessary adjustments.



## SEALS

The following types of shaft seal systems are available:

- lip seal in suitable material
- stuffing box with gland follower and PTFE or Kevlar treated rings
- compact rotary mechanical seals with minimal axial size, pinned stationary part, dimension according to DIN 24960. The available materials are: stainless steel, carbon, tungsten carbide, silicon carbide, ceramic, rulon. Material combinations can be chosen according to the handled fluid. The elastomers (OR) available are: NBR, EPDM, Viton, FEP (PTFE-coated silicon).

# TYPES OF SEAL

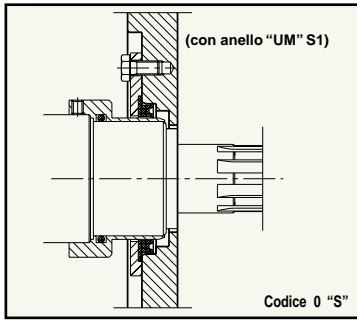

## LIP SEAL

This is the simplest and cheapest type of seal, consisting of a Viton UM ring (for lubricating products, animal and vegetable oils, greases, cosmetic creams, etc) or S1 polymer (for chocolate). Both for low pressure and low speed applications.

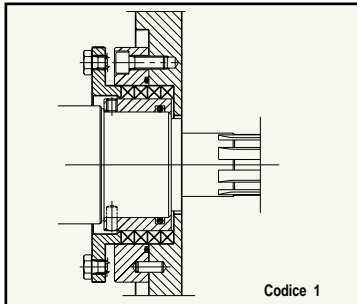
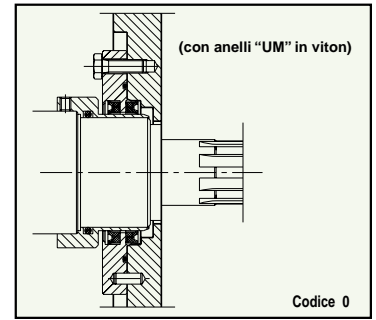

## PACKING GLAND

This is the typical traditional system, consisting of a gland follower pushing on Teflon-treated braid rings which slide on a sleeve fixed to the rotating shaft. This type of seal is now rarely used since in order to function properly it must leak to ensure that the entire braid pack is lubricated by the product (to prevent overheating and guarantee good life). The gland follower must be tightened at regular intervals to compensate wear in the braid rings. This type of seal is still suitable for glueing products, flushing of mechanical seal is not admitted, such as: glues, resins, rubber cements, molasses, etc.

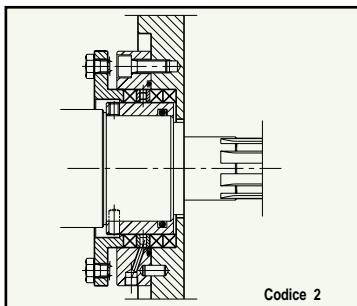

## FLUSHED PACKING GLAND

This is a variant of the packing gland with the addition of an hydraulic ring for flushing of the liquid (usually water). This enables the braid packing to be kept wet and cool in order to prevent overheating when pumping hot products and also creates an hydraulic barrier between atmosphere and pumped product.

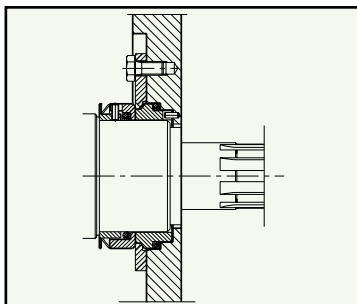

## BALANCED ROTARY MECHANICAL SEAL

This is the most widely used kind of seal. Simple and hygienic, it requires no adjustment or maintenance apart from replacement due to wear. Depending on the type, the two mating faces can be in stainless steel/carbon (code 3) or:

- tungsten carbide/carbon (code 4)
- tungsten carbide/tung.carbide (code 5)
- ceramic/carbon (code 6)
- ceramic/rulon (code 7)
- silicon carbide/sil. carbide (code 8)

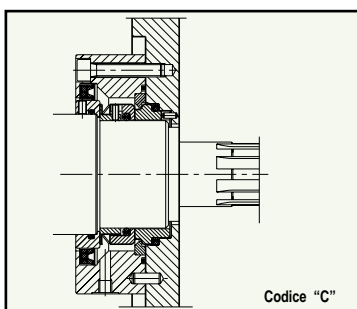

## FLUSHED BALANCED ROTARY MECHANICAL SEAL

All the simple compact seals used can be flushed with the option of a flushing seal box with a radial UM or lip ring liquid seal. Water or some other non-polluting liquid flows at low pressure in the flushing seal box and washes the seal constantly so as to cool, lubricate if it is running dry, and prevent solid deposits from sugar syrups, tartrates etc. On the surfaces of the seal, as this would affect its working and life.

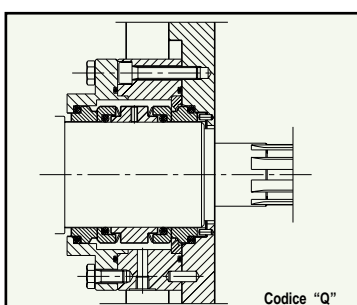

## FLUSHED DOUBLE BALANCED ROTARY MECHANICAL SEAL

It is an application with the same principle of the flushed balanced rotary mechanical seal, with the difference in the sealing of the flushing liquid made by the mechanical seal. In this case the flushing liquid can circulate at an higher pressure then the one of the transferring liquid with which it must be compatible.

# SELECTING PUMP ACCORDING TO FLOW AND PRODUCTS VISCOSITY

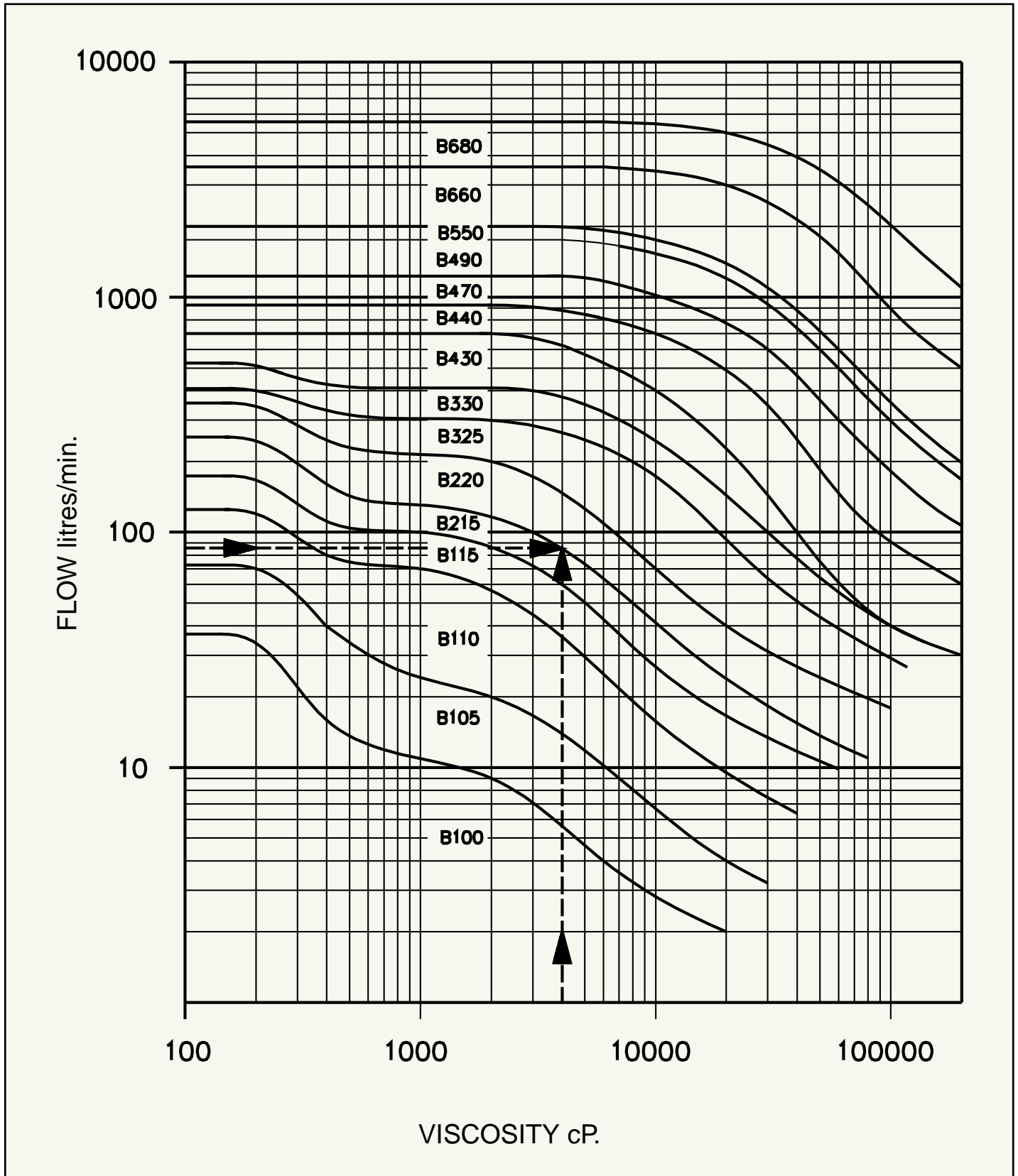

The curves on this chart define the fields of operation of the various sizes of pump, enabling a preliminary selection to be made according to viscosity/flow.

For example:

viscosity = 4000 cP.

flow = 85 l/min

The appropriate pump is the model B 220.

This preliminary selection should subsequently be checked on the pump installation layout, taking into consideration: nature of the liquid to be pumped, NPSH available, suction distance, vapour pressure and discharge head losses.



# TECHNICAL DATA

## OVERALL DIMENSIONS IN MM.

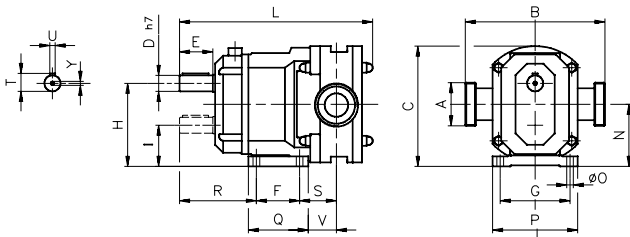

POS.	TYPE OF PUMP WITH GAS - BSP PORTS																
	B100	B105	B110	B115	B215	B220	B325	B330	B430	B440	B470	B490	B550	B660	B680		
A	1"	1 1/2"	1 1/2"	1 1/2"	1 1/2"	2"	2 1/2"	3"	3"	4"	4"	4"					
B	160	170	170	170	208	208	236	236	335	335	385	385					
C	115.5	181	181	181	235.5	235.5	270	270	367.5	367.5	442.5	442.5	515	690	690		
D	18	24	24	24	28	28	35	35	48	48	55	55	55	80	80		
E	45	50	50	50	55	55	65	65	85	85	110	110	110	140	140		
F	65	65	65	65	90	90	120	120	140	140	150	150	200	300	300		
G	105	105	105	105	125	125	140	140	190	190	250	250	300	400	400		
H	80	125	125	125	165	165	190	190	255	255	300	300	350	480	480		
I		62	62	62	90	90	100	100	130	130	160	160	178	250	250		
L	265	290.5	290.5	302.5	365.5	380.5	459	474	543.5	543.5	654	654	637	807	867		
N	58.6	93.5	93.5	93.5	127.5	127.5	145	145	192.5	192.5	230	230	264	365	365		
O	9	10	10	10	12	12	14	14	18	18	22	22	19	26	26		
P	125	128	128	128	152	152	174	174	235	235	300	300	350	460	460		
Q	85	90	90	90	130	130	170	170	195	195	255	255	250	360	360		
R	108	115.5	115.5	115.5	136.5	136.5	167	167	206.5	206.5	255	255	227	283	283		
S	52	55.5	55.5	55.5	67	67	78	78	94	94	109	116.5	143.5	173	106.5	122	152
T	20.5	27	27	27	31	31	38.5	38.5	52	52	60	60	60	85	88		
U	6	8	8	8	8	8	10	10	14	14	16	16	16	22	22		
V	42	42.5	42.5	54	52	61	62	71	76.5	84	63.5	93	81.5	92	122		
Y		M6	M6	M6	M8	M8	M10	M10	M12	M12	M12	M12	M12	M16	M16		
Kg.	10.5	20	20	20	41	43	63	65	130	135	225	233	270	610	670		

### Pumps with DIN 11851 ports

A	DN25	DN40	DN40	DN40	DN50	DN65	DN80	DN80	DN80	DN100	DN100	DN100	DN125		
B	160	210	210	210	248	248	296	296	395	395	445	445	632		

## HYDRAULIC TECHNICAL DATA

PUMP SIZE	VOLUMETRIC FLOW l/100 rev.	MAX. SPEED r.p.m.	MAX. POWER KW	MAX. PRESSURE (bar)					FITTINGS STANDARD	
				ST with shaft		SM with shaft		HP	DN	Inches
				316 S.S.	Duplex	316 S.S.	Duplex			
B100	3	1400	1,5	7	10	-	-	-	25	1"
B105	7	1000	4	10	13	15	18	-	40	1 1/2"
B110	12	1000	4	10	13	15	18	20	40	1 1/2"
B115	18	1000	5,5	7	10	12	15	-	40	1 1/2"
B215	23	950	7,5	10	13	15	18	20	40	1 1/2"
B220	34	950	7,5	7	10	12	15	-	50	2"
B325	55	720	18,5	10	13	15	18	20	65	2 1/2"
B330	70	720	18,5	7	10	12	15	-	80	3"
B430	116	600	30	10	13	15	18	20	80	3"
B440	155	600	30	7	10	12	15	-	100	4"
B470	240	500	45	10	13	15	18	20	100	4"
B490	330	500	45	7	10	12	15	-	100	4"
B550	400	500	45	5	-	7	-	-	125	5"
B660	700	500	75	7	-	-	-	-	150	6"
B680	1050	500	75	4	-	-	-	-	200	8"

AVAILABLE ROTOR TYPE	PUMP SIZES														
	B100	B105	B110	B115	B215	B220	B325	B330	B430	B440	B470	B490	B550	B660	B680
Stainless steel tri-lobe			●	●	●	●	●	●	●	●	●	●	●	●	●
Stainless steel gear rotor	●	●													
Acteon dual wing rotary piston°	●	●	●	●	●	●	●	●	●	●	●	●	●		
Acteon tri-lobe/gear rotor*	●	●	●	●											
Stainless steel bi-lobe	●			●			●	●	●	●	●	●	●		
Rubber coated tri-lobe (five-lobe*)	●	●	●	●	●	●								●	
Rubber coated bi-lobe						●	●	●	●				●		

° Bi-lobe for B100 - \* For B100 and B105

## SOME PUMPED PRODUCTS

vinegar	ketchup	tomato purée
distilled water	milk	diced tomaatoes
hydrogen peroxide	condensed milk	perfumes
alcohol	latex	mashed potato
adhesives	yeast	fruit purée
beer	liquor	cottage cheese
soup	lotions	brine
butter	mayonnaise	saucers
curd	malt	blood
mincemeat	margarine	soap
chocolate	jam	syrup
glue	marzipan	shampoo
cream	molasses	caustic soda
toothpaste	mushroom	galvanic solution
detergents	honey	sugar solution
emulsions	coconut oil	solvents
explosives	olive oil	fruit juice
essences	baby food	tea
milk enzymes	sponge-cake	surfactants for
strawberries	cream	detergents
ice-cream	paraffin	tointment
gelatine	suppository	eggs
icing	paste	vaseline
glycerine	hand cleaning	paint
guucose	paste	wine
animal grease	polymers	yoghurt
	fruit pulp	

## INDUSTRIAL APPLICATIONS

**PHARMACEUTICAL:** paste, plasma, icing, glucose, etc.

**COSMETICS:** beauty creams, toothpaste, shampoo, detergents, lotions

**CHEMICAL:** paints, enamels, detergents, polymers, resins, dodecylbenzene, acids, etc.

**BEVERAGES:** wine, alcohol, beer, soft drinks, syrup, tea, fruit juice, grape juice, mineral water

**FOOD:** fruit and tomato concentrates, fruit and vegetable salads, preserved vegetables, sauces, mayonnaise, homogenized meat, starch, vegetable purées, etc.

**CONFECTIONERY:** chocolate, cream, sponge-cake, products with yeast, fillings, fats, margarine, jam, marmalade

**DAIRY:** milk and its products, sofft cheese, yoghurt, fruit for yoghurt, butter, curd, cream, whey, etc.

## DEALER



**OMAC S.r.l. POMPE** Via G. Falcone, 8 - 42048 RUBIERA (RE) - ITALY  
 TEL. 0522 629371-629923 - FAX 0522 628980  
 www.omacpompe.com - E-mail: commerciale@omacpompe.com